

9 Chemical Management Systems

- Mixing Stations™
- Level Master™ Systems
- Chemical Transfer Systems
- Accessories



Lafferty
EQUIPMENT MANUFACTURING LLC

CATALOG 9

Chemical Management Systems

**Chemical
Application
Equipment**

www.LaffertyEquipment.com

5614 Oak Grove Road • North Little Rock, AR 72118

Phone: 800-999-2820 / 501-851-2820 • Fax Orders: 800-699-3719

Chemical Management Systems

Lafferty's Complete Balanced System Approach

The team at Lafferty Equipment puts more than a century of combined manufacturing and in-the-field experience into the equipment that we offer. Our approach is to provide a complete, balanced system right out of the box for ease of installation and trouble-free performance.

Lafferty Equipment's core product offering is the widest range of chemical application and chemical management equipment available in the marketplace.

If a standard product does not meet the need, we have many specialized systems not listed in this catalog, which may provide the solution. If not, we will work with you to create a system to meet the client's specific requirements.

Our passionate focus on superior quality, outstanding reliability and attention to detail ensures years of consistent operational performance and peace of mind.

Focus on Performance

- Dedicated Research and Development team
- Application-specific designs to create integrated balanced systems
- Machined injector bodies engineered for their specific, intended use
- Reliable, precision metering options

Focus on Quality, Reliability and Durability

- Designed to endure heavy usage in industrial settings with minimal maintenance requirements
- Lafferty's proprietary stainless steel and polypropylene components are precision machined on state-of-the-art CNC and traditional machine tools in Lafferty's manufacturing facility in Arkansas.
- Extensive testing of all finished products
- Material selection for optimum chemical and industry compatibility, with all wetted parts chemically resistant

Focus on Service

- Dedicated to superior customer service and support
- Prompt order shipment
- Detailed website and catalog information for equipment selection
- Comprehensive Installation and Operation Instructions



LAFFERTY MIXING STATIONS™ are water-driven venturi proportioners that accurately dilute chemical concentrates to required ratios and fill any size container with diluted, ready-to-use (RTU) chemical solution. Lafferty Mixing Stations eliminate the need for manual mixing, optimizing chemical utilization, employee safety and labor efficiency.

Offered with Lafferty's signature heavy-duty stainless steel mounting enclosures.

PUSH LEVER & BALL VALVE MIXING STATIONS

REQUIRES: 25-125 PSI WATER

- **Push Lever Mixing Stations** require the user to push and hold the lever to dispense, preventing accidental overfilling of containers.
- **Ball Valve Mixing Stations** provide hands-free dispensing of chemical solutions.
- Choice of left or right side garden hose water inlet
- All Mixing Stations can be plumbed in series
- Choice of three water flow rates for filling small to large containers
- Certified to ASSE Standard 1055 for backflow prevention



Extra heavy-duty brass valve for unrivalled durability

REQUIREMENTS / SPECIFICATIONS

Water Pressure	25 - 125 PSI	1.7 - 8.6 bar
Water Flow Rate	@ 40 PSI	@ 2.8 bar
Bottle Fill (BF)	0.6 gpm	2.3 lpm
Low Flow (LF)	2.1 gpm	7.9 lpm
High Flow (HF)	4.5 gpm	17.0 lpm

- **When ordering, specify the flow for each push lever or ball valve.** Any combination may be selected. (Example: Model 981400, 4-Way Push Lever — HF, HF, LF, BF)
- All mixing stations are built with EPDM check valves (Viton optional — specify at time of order)

Includes

- Stainless steel mounting enclosure
- Integrated hose connection vacuum breakers
- Polypropylene injector bodies
- Color-coded metering tips (20)
- Metering tip driver

Model #	Description
981100	1-Way Push Lever Mixing Station
981200	2-Way Push Lever Mixing Station
981300	3-Way Push Lever Mixing Station
981400	4-Way Push Lever Mixing Station



STAINLESS STEEL MIXING STATIONS: For Solvents and Other Harsh Chemicals

- Available as 1-Way or 2-Way Ball Valve units

Water Flow Rate	@ 40 PSI	@ 2.8 bar
Low Flow	<i>*Specify flow rate — HF (high flow) or LF (low flow) — at time of order</i> 2.0 gpm	7.6 lpm
High Flow	4.0 gpm	15.1 lpm

Includes:

- Stainless steel mounting enclosure;
- Integrated hose connection vacuum breakers;
- Machined stainless steel injector body;
- Color-coded metering tips (20);
- Metering tip driver;
- Solvent resistant pick-up and discharge tubes

Certified to ASSE Standard 1055 for backflow prevention

Model #	Description
985100SS	1-Way Ball Valve SS Mixing Station
985200SS	2-Way Ball Valve SS Mixing Station



Model #	Description
985100	1-Way Ball Valve Mixing Station
985200	2-Way Ball Valve Mixing Station
985300	3-Way Ball Valve Mixing Station
985400	4-Way Ball Valve Mixing Station
985450	5-Way Ball Valve Mixing Station

CHEMICAL MANAGEMENT

DRUM MOUNT AND PAIL/JUG MOUNT MIXING STATIONS

REQUIRES: 25-125 PSI WATER

- Ball valve for hands-free dispensing of chemical solutions
- Mount directly to the chemical container
- Drum Mount body has fine and course threads to fit the bung opening of most 55-gallon chemical drums.
- Pail/Jug Mount fits onto 1-gallon jugs, pull-up spouts on 5-gallon pails, or any container with 38mm OD threads



REQUIREMENTS / SPECIFICATIONS

Water Pressure	25 - 125 PSI	1.7 - 8.6 bar
Water Flow Rate	@ 40 PSI	@ 2.8 bar
	4.0 gpm	15.1 lpm

Includes

- Machined polypropylene injector body
- Integrated vacuum breaker (backflow preventer)
- Color-coded metering tips (20) and metering tip driver



Model #	Description
985500	Drum Mount Uni-Body™ Mixing Station <i>(Also available as a high concentrate model – See details online – 985500HC)</i>
985512	Pail/Jug Mount Uni-Body™ Mixing Station

HIGH CONCENTRATE MIXING & FILLING STATIONS

REQUIRES: 40-80 PSI WATER

- Lafferty's **High Concentrate Mixing Stations** and **Filling Stations** will deliver a true 1:1 dilution ratio with water-thin chemical. (Included metering plugs provide 2:1 and 3:1 ratios.) Chemical viscosity will affect dilution ratios.
- **Mixing Stations** are offered with a choice of five water flow rates.
- **Filling Stations** include a trigger gun and are offered with a choice of two water flow rates. Also offered are 2-Way units for alternating between different ratios of the same chemical or between two compatible chemicals.

REQUIREMENTS / SPECIFICATIONS

Water Pressure	40 - 80 PSI	2.8 - 5.5 bar
Water Flow Rate	@ 40 PSI	@ 2.8 bar
105HC	1.0 gpm	3.8 lpm
207HC	2.0 gpm	7.6 lpm
414HC	4.0 gpm	15.1 lpm
621HC	6.0 gpm	22.7 lpm
828HC	7.6 gpm	28.8 lpm

Discharge Hose

ID		
105HC	1/2 in.	12.7 mm
207HC	3/4 in.	19.1 mm
414HC	3/4 in.	19.1 mm
621HC	1 in.	25.4 mm
828HC	1 in.	25.4 mm
Length		
Mixing Stations	10 ft.	3.0 m
Filling Stations	15 ft.	4.6 m

Includes

- Machined polypropylene injector body
- Stainless steel mounting enclosure
- Stainless steel ball valve
- Metering plugs for a 2:1 or 3:1 ratio
- Color-coded metering tips (20) and metering tip driver (105 and 207 models)
- Discharge hose
- Polypropylene trigger gun with Viton seals (Filling Station models)



Model #	Description
980105	105HC Mixing Station
980207	207HC Mixing Station
980414	414HC Mixing Station
980621	621HC Mixing Station
980828	828HC Mixing Station



Model #	Description
980005	105HC Filling Station
980006	2-Way 105HC Filling Station
980007	207HC Filling Station
980008	2-Way 207HC Filling Station

Trigger gun included with HC Filling Stations



HIGH VOLUME MIXING STATIONS

REQUIRES: 35-125 PSI WATER

- Lafferty High Volume Mixing Stations quickly fill floor scrubbers and other large containers, minimizing fill time.
- Flow rates range from 5 gpm @ 40 psi water to 12 gpm @ 40 psi
- Units can be fitted with optional longer discharge hose and either a trigger gun or a wand assembly with shut-off ball valve.

517 Trigger Gun Mixing Station

- Allows for hands-on, controlled filling and automatic shutoff with the included "filling station style" trigger gun
- Features an extended length hose for filling large equipment at a distance

REQUIREMENTS / SPECIFICATIONS

Water Pressure	35 - 125 PSI	2.4 - 8.6 bar
Water Flow Rate	@ 40 PSI	@ 2.8 bar
517 Trigger Gun	5.0 gpm	18.9 lpm
High Volume SS	9.4 gpm	35.6 lpm
High Volume	9.9 gpm	37.5 lpm
High Volume 1242	12.0 gpm	45.4 lpm
Discharge Hose		
ID	3/4 in.	19.1 mm
Length	10 ft.	3.0 m
517 Trigger Gun	15 ft.	4.6 m

Includes

- Machined injector body/bodies (polypropylene or stainless steel)
- Stainless steel mounting enclosure
- Stainless steel ball valve
- Color-coded metering tips (20)
- Metering tip driver
- Discharge hose
- Trigger Gun (model #985830, only — optional with other models)



Model #	Description
985830	517 Trigger Gun Mixing Station
985835	High Volume Mixing Station
985835SS	High Volume SS Mixing Station
985837	2-Way High Volume Mixing Station
985838	3-Way High Volume Mixing Station
985845	High Volume 1242 Mixing Station
Option:	
491404-A	Chemical Pick-up Assembly, Viton (1/2" tube)
<i>To achieve stronger chemical concentrations or when using a viscous chemical, install a second chemical pick-up assembly in the unit</i>	

Higher volume units available on request.



The filling-station style trigger gun (shown at right at a larger scale to show details) allows for hands-on, controlled filling and automatic shutoff. This trigger gun is included with #985830, optional with other high volume mixing stations. (See model # online for options details.)

GEMINI™ MIXING STATIONS

REQUIRES: 25-125 PSI WATER

- For mixing two chemicals, Gemini Mixing Stations feature Lafferty's unique twin pick-up Gemini™ proportioner, an industry-leading design that incorporates two completely separated venturis in one injector body.
- Precise, independent dilution of two chemicals with differing viscosities and dilution ratios.
- The two chemical concentrates cannot cross mix and the diluted solutions mix only as they are discharged.
- Choice of Push Lever or Ball Valve operated models

REQUIREMENTS / SPECIFICATIONS

Water Pressure	25 - 125 PSI	1.7 - 8.6 bar
Water Flow Rate	@ 40 PSI	@ 2.8 bar
Gemini Model 25	2.2 gpm	8.3 lpm
Gemini Model 150	7.0 gpm	26.5 lpm

Includes

- Machined polypropylene injector body
- Stainless steel mounting enclosure
- Integrated hose connection vacuum breaker (982025PL & 982025)
- Color-coded metering tips (20)
- Metering tip driver



Model #	Description
982025PL	Gemini Model 25 Push Lever Mixing Station
982025	Gemini Model 25 Mixing Station
982150	Gemini Model 150 Mixing Station*

*Requires 3/4" water supply line



LAFFERTY LEVEL MASTER SYSTEMS are float valve operated proportioners, designed to maintain the desired level of ready-to-use (RTU) chemical solution in any reservoir. Lafferty's novel design incorporates machined, solid blocks of chemical-resistant polypropylene to reduce chemical leak points and enhance overall durability and function.

Standard Level Master Systems will produce RTU solution from one chemical concentrate. Available in two styles — bracket mounted or lid mounted, which are integrated with a tank lid to fit optional 7-gallon, 16-gallon, or 20-gallon tanks. (Lid-mounted High Flow Level Master Systems include a 60-gallon tank.)

Gemini Level Master Systems (see page 9) will separately proportion two chemicals before mixing the two solutions as they flow into the holding tank.

LEVEL MASTER™ SYSTEMS

REQUIRES: 25-80 PSI WATER

- Features a single water-driven venturi proportioner to dilute one chemical to the required ratio
- Single float design or dual float design for locations where preventing accidental overflow is critical. A second, smaller float provides fail-safe protection.
- Unsinkable solid polypropylene float suspended by a rigid "push rod" ensures smooth operation and prevents the float valve from sticking in the open position
- Chemical resistant wetted components ensure years of outstanding performance with minimal maintenance
- Downstream check valve prevents back-flow of liquid or vapor into the float valve to eliminate the potential for damage to internal components
- Industrial-strength design holds up in tough environments

Two styles

- Systems with heavy-duty stainless steel bracket for open tanks
 - *SS Bracket* clamps to the wall of an open tank
 - *SSHM Bracket* – horizontal mount – bolts to the top of a user-supplied tank
- Systems integrated into a tank lid designed to fit a 7-gallon, 16-gallon or 20-gallon tank (*Can also be fitted to an optional 60-gallon tank.*)

REQUIREMENTS / SPECIFICATIONS

Water Pressure	25 - 80 PSI	1.7 - 5.5 bar
Water Flow Rate	@ 40 PSI	@ 2.8 bar
	2.4 gpm	9.1 lpm

Includes

- Water supply inlet strainer
- Water supply shut-off ball valve
- Machined polypropylene injector body
- Magnetic float valve (989303) — *two float valves, primary and fail-safe, for models 989304; 989308; 989312* — with solid polypropylene float(s) suspended by rigid CPVC push rod
- Stainless steel / Viton back-flow prevention check valve
- Color-coded metering tips (20) to set dilution ratios
- Metering tip driver
- Stainless steel bracket or plastic lid for a paired tank as indicated by model number (*Paired tank not included.*)

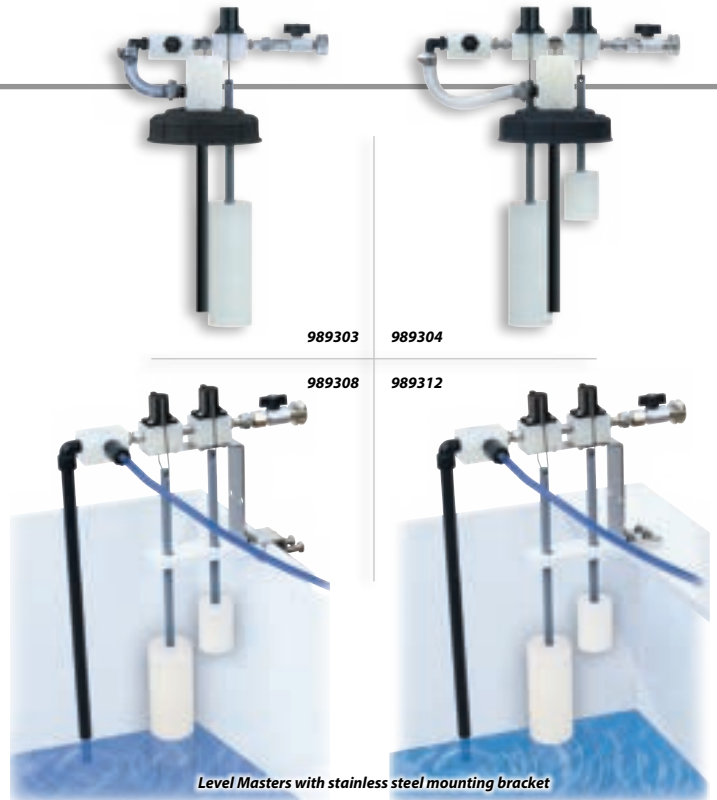
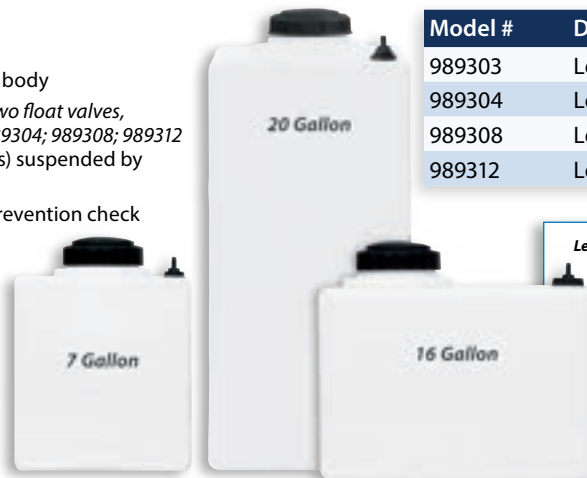

Model #	Description
989303	Level Master™ (Single Float - No Tank)
989304	Level Master™ (No Tank)
989308	Level Master™ with SS Bracket
989312	Level Master™ with SSMH Bracket

Level Master™ Tanks are heavy-duty HDPE tanks designed for use with a Level Master lid assembly (sold separately). Each tank includes inlet and discharge assemblies with hose barbs.

Level Master Tank Sizes (Specify When Ordering)
 7 Gallon# 709170
 16 Gallon# 709171
 20 Gallon# 709172

HIGH FLOW LEVEL MASTER SYSTEMS

REQUIRES: 35-125 PSI WATER, COMPRESSED AIR AND CHEMICAL CONCENTRATE

- Float-valve-operated proportioners, designed to quickly replenish and maintain the desired level of ready-to-use (RTU) chemical solution in any reservoir.

Two Styles

- Systems with heavy-duty stainless steel bracket for open tanks
 - *SS Bracket* clamps to the wall of an open tank
 - *SSHM Bracket* – horizontal mount – bolts to the top of a user-supplied tank
- Systems integrated with the lid of the included 60-gallon tank

Operation

- The float valve triggers the air-activated solenoid(s) to start and stop the flow of water through the high volume venturi proportioner(s).
- Draws chemical concentrate from user-supplied bulk container(s), dilutes the chemical(s) to required ratio and delivers the solution to holding tank(s)
- Dilution ratios are controlled using precision metering tips

Features

- Dual magnetic float valve design includes a primary valve to regulate normal operation and a secondary fail-safe valve to shut off the system if the primary float valve malfunctions
- Unsinkable solid polypropylene floats suspended by rigid "push rods" ensure smooth operation and prevent the float valves from sticking in the open position
- Chemical resistant wetted components ensure years of outstanding performance with minimal maintenance
- Industrial-strength design holds up in tough environments
- Complete with hook-up connections for a compressed air-operated Lafferty Pumping System (or a user-supplied pumping system)
- Choice of two flow rates. Replenishes RTU solution at:
 - 10.6 gpm @ 40 PSI – 989100; 989106
(Includes a single high flow venturi proportioner)
 - 21.2 gpm @ 40 PSI – 989101; 989108
(Includes two high flow venturi proportioners)

REQUIREMENTS / SPECIFICATIONS

Compressed Air	<1 cfm	<28.3 lpm
Water Pressure	35 - 125 PSI	2.4 - 8.6 bar
Water Flow Rate	@ 40 PSI	@ 2.8 bar
989100 / 989106	10.6 gpm	40.1 lpm
989101 / 989108	21.2 gpm	80.3 lpm

Includes

- Stainless steel Level Master mounting bracket --for use with user-supplied, open solution tank (989100; 989101)
- One, 60-gallon high density polyethylene (HDPE) chemical tank with drain (989106; 989108)
- Two magnetic float valves (primary and fail-safe) with solid polypropylene floats suspended by rigid CPVC push rods
- Air inlet ball valve
- High flow proportioner(s) with machined polypropylene injector body and stainless steel mounting plate
- Manual on/off ball valve, for use when emptying solution reservoir
- Air-activated water solenoid(s)
- Color coded metering tips for up to 21 dilution ratios and metering tip driver (1 set per proportioner)

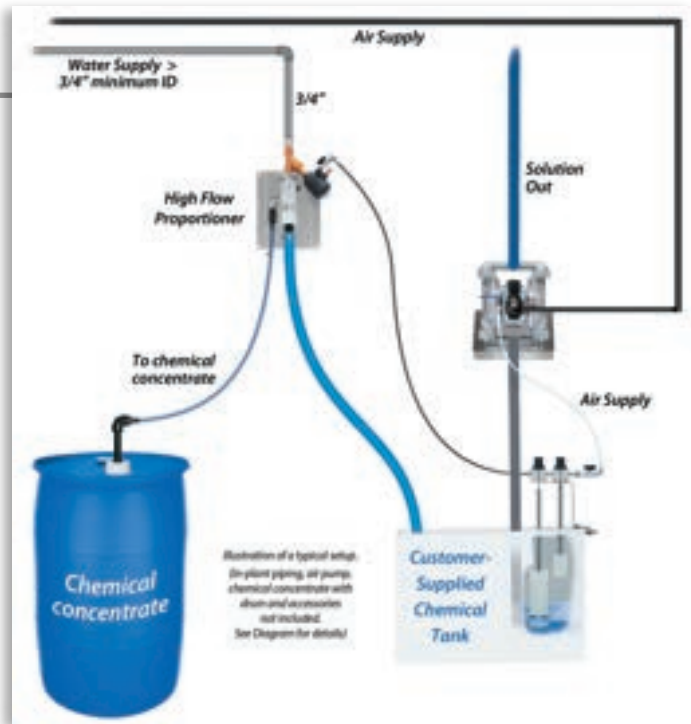

▲ 10 GPM High Flow Level Master System, illustrated above, includes one, wall-mounted proportioner. The 20 GPM system (989101) includes two proportioners.

Model #	Description
989100	10 GPM High Flow Level Master™
989101	20 GPM High Flow Level Master™

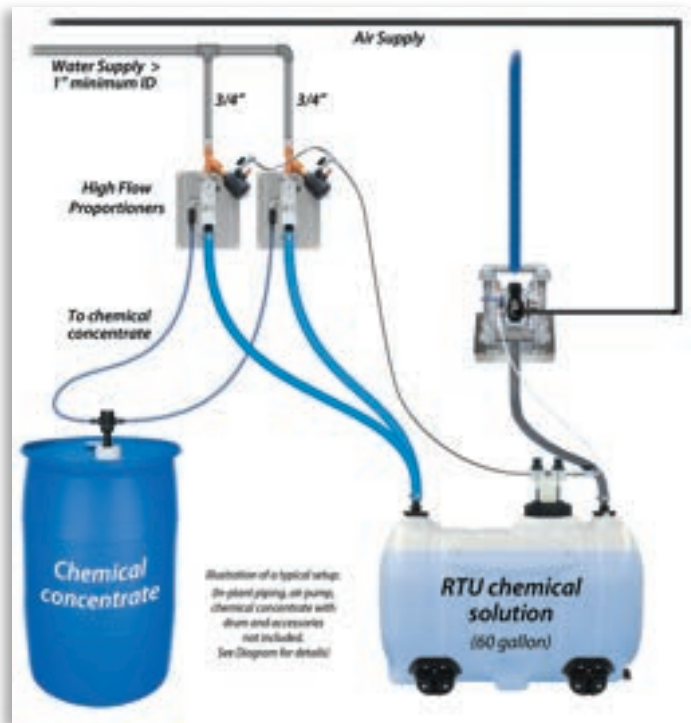

▲ 60/20 Level Master System, illustrated above, includes two, wall-mounted proportioners and the 60-gallon solution tank. The 60/10 system (989106) includes one proportioner and the tank.

Model #	Description
989106	60/10 High Flow Level Master™
989108	60/20 High Flow Level Master™

CHEMICAL MANAGEMENT

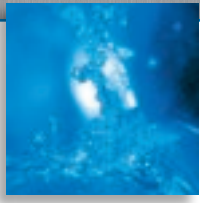

LAFFERTY GEMINI LEVEL MASTERS allow precise, independent dilution of two chemicals, with differing viscosities and dilution ratios, and are float-valve-operated proportioners, designed to quickly replenish and maintain the desired level of ready-to-use (RTU) chemical solution in any reservoir. The float valve triggers an air-activated solenoid to start and stop the flow of water through the high flow Gemini venturi proportioners. A secondary float valve provides fail-safe protection.

Available in two styles — bracket mounted or lid mounted, which are integrated with a tank lid to fit optional 7-gallon, 16-gallon, or 20-gallon tanks. **Gemini High Flow Level Master Systems** are available as integrated systems complete with 60-gallon tanks.

GEMINI LEVEL MASTER SYSTEMS

REQUIRES: 25-80 PSI WATER, COMPRESSED AIR AND TWO CHEMICAL CONCENTRATES

- Automatically maintains a pre-set level of ready-to-use chemical solution in a paired tank (*sold separately, see options*)
- The industry-leading Gemini™ proportioner dilutes two chemical concentrates and blends them downstream so that the concentrates never come into direct contact
- Designed to withstand demanding operating environments and the aggressive nature of chlorine dioxide
- Dual magnetic float valve design includes a primary valve to regulate normal operation and a secondary fail-safe valve to shut off the system if the primary float valve malfunctions
- Unsinkable solid polypropylene floats suspended by rigid "push rods" ensure smooth operation and prevent the float valves from sticking in the open position
- Downstream check valve prevents back-flow of liquid or vapor into the float valves to eliminate the potential for damage to internal mechanisms

Two styles

- Systems with heavy-duty stainless steel bracket for open tanks
 - *SS Bracket* clamps to the wall of an open tank
 - *SSHM Bracket* – horizontal mount – bolts to the top of a user-supplied tank
- Systems integrated into a tank lid designed to fit a 7-gallon, 16-gallon or 20-gallon tank (*also can be fitted to an optional 60-gallon tank*)

REQUIREMENTS / SPECIFICATIONS

Water Pressure	25 - 80 PSI	1.7 - 5.5 bar
Water Flow Rate	@ 40 PSI	@ 2.8 bar
	2.4 gpm	9.1 lpm

Includes

- Water supply inlet strainer
- Water supply shut-off ball valve
- Machined polypropylene Gemini™ injector body
- Two machined magnetic float valves (primary and fail-safe) with solid polypropylene floats suspended by rigid CPVC push rods
- Stainless steel / Viton back-flow prevention check valve
- Color-coded metering tips (20) to set dilution ratios
- Stainless steel bracket or plastic lid for a paired tank as indicated by model number (*Paired tank not included.*)

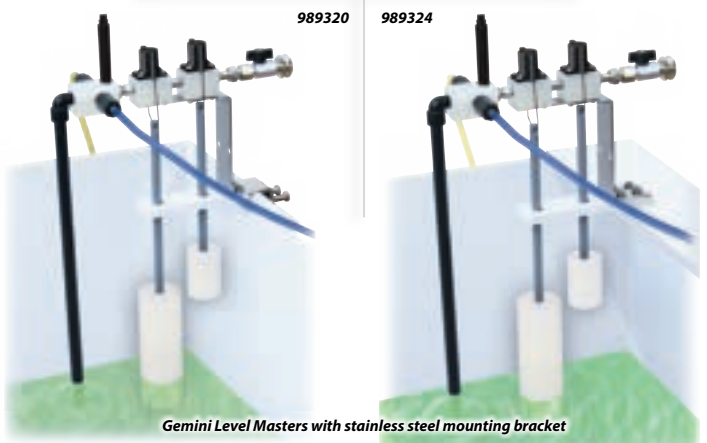
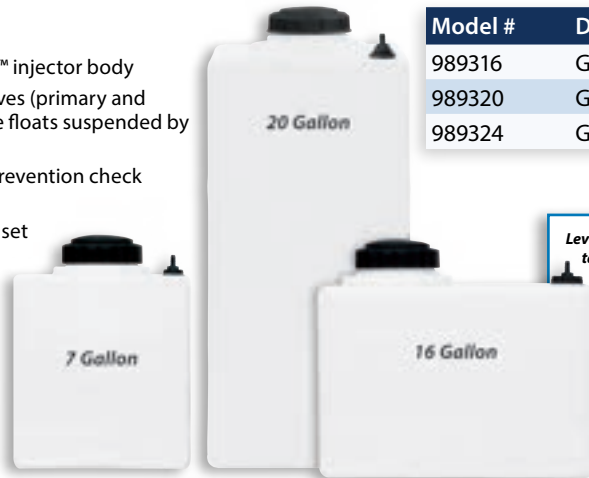

Gemini Level Masters with stainless steel mounting bracket

Model #	Description
989316	Gemini Level Master™ (No Tank)
989320	Gemini Level Master™ with SS Bracket
989324	Gemini Level Master™ with SSHM Bracket

Level Master™ Tanks are heavy-duty HDPE tanks designed for use with a Level Master lid assembly (sold separately). Each tank includes inlet and discharge assemblies with hose barbs.

Level Master Tank Sizes (Specify When Ordering)
 7 Gallon# 709170
 16 Gallon# 709171
 20 Gallon# 709172

GEMINI HIGH FLOW LEVEL MASTER SYSTEMS

REQUIRES: 35-125 PSI WATER, COMPRESSED AIR AND TWO CHEMICAL CONCENTRATES

The unique Gemini™ proportioner draws two chemical concentrates and blends them downstream after dilution

- Float-valve-operated proportioners, designed to quickly replenish and maintain the desired level of ready-to-use (RTU) chemical solution in any reservoir.

Two Styles

- Systems with heavy-duty stainless steel bracket for open tanks
 - *SS Bracket* clamps to the wall of an open tank
 - *SSHM Bracket* – horizontal mount – bolts to the top of a user-supplied tank
- Systems integrated with the lid of the included 60-gallon tank

Operation

- The float valve triggers the air-activated solenoid(s) to start and stop the flow of water through the high volume venturi proportioner(s).
- Draws chemical concentrate from user-supplied bulk container(s), dilutes the chemical(s) to required ratio and delivers the solution to holding tank(s)
- Dilution ratios are controlled using precision metering tips

Features

- Dual magnetic float valve design includes a primary valve to regulate normal operation and a secondary fail-safe valve to shut off the system if the primary float valve malfunctions
- Unsinkable solid polypropylene floats suspended by rigid "push rods" ensure smooth operation and prevent the float valves from sticking in the open position
- Chemical resistant wetted components ensure years of outstanding performance with minimal maintenance
- Industrial-strength design holds up in tough environments
- Complete with hook-up connections for a compressed air-operated Lafferty Pumping System (or a user-supplied pumping system)
- Choice of two flow rates. Replenishes RTU solution at:
 - 7.0 gpm @ 40 PSI – 989072; 989126
(Includes a single Gemini high flow venturi proportioner)
 - 14.0 gpm @ 40 PSI – 989074; 989128
(Includes two Gemini high flow venturi proportioners)

REQUIREMENTS / SPECIFICATIONS

Compressed Air	<1 cfm	<28.3 lpm
Water Pressure	35 - 125 PSI	2.4 - 8.6 bar
Water Flow Rate	@ 40 PSI	@ 2.8 bar
989072 / 989126	7.0 gpm	26.5 lpm
989076 / 989128	14.0 gpm	53.0 lpm

Includes

- Stainless steel Level Master mounting bracket --for use with user-supplied, open solution tank (989072; 989074)
- One, 60-gallon high density polyethylene (HDPE) chemical tank with drain (989126; 989128)
- Two magnetic float valves (primary and fail-safe) with solid polypropylene floats suspended by rigid CPVC push rods
- Air inlet ball valve
- High flow proportioner(s) with machined polypropylene Gemini™ injector body and stainless steel mounting plate
- Manual on/off ball valve, for use when emptying solution reservoir
- Air-activated water solenoid(s)
- Color coded metering tips for up to 21 dilution ratios and metering tip driver (1 set per proportioner)

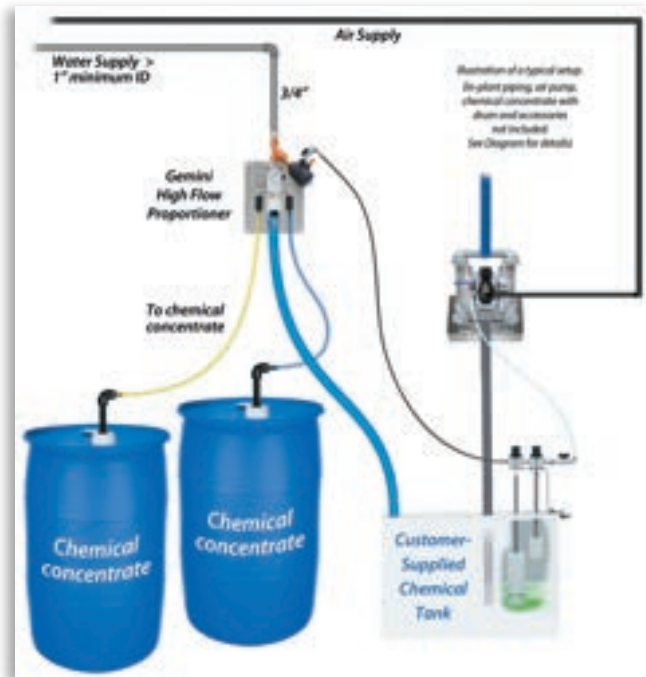

▲ 7 GPM High Flow Level Master System, illustrated above, includes one, wall-mounted proportioner. The 14 GPM system (989074) includes two proportioners.

Model #	Description
989072	7 GPM Gemini High Flow Level Master™
989074	14 GPM Gemini High Flow Level Master™

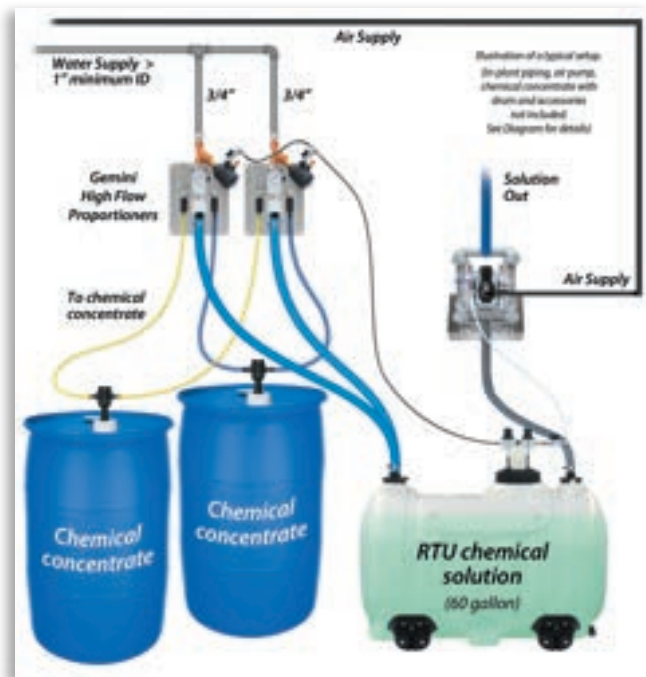

▲ 60/14 Level Master System, illustrated above, includes two, wall-mounted proportioners and the 60-gallon solution tank. The 60/7 system (989126) includes one proportioner and the tank.

Model #	Description
989126	60/7 Gemini High Flow Level Master™
989128	60/14 Gemini High Flow Level Master™



Sandpiper Pump

1/2" or 1" AODD
Santoprene Diaphragm
Teflon Optional

LAFFERTY CHEMICAL TRANSFER / PUMPING SYSTEMS use compressed air-operated double diaphragm pumps to transfer chemical concentrates or diluted ready-to-use solution from bulk containers to any other container. 1/2" and 1" AODD systems features include:

- Diaphragm upgrades available to suit chemical compatibility needs;
- Wall mount models include Lafferty's signature heavy duty stainless steel mounting enclosures or brackets and portable models feature heavy duty stainless steel carts;
- A variety of electronic timer controllers available to fit system control needs

COMPRESSED AIR DRIVEN TRANSFER / PUMPING SYSTEMS

REQUIRES: COMPRESSED AIR AND CHEMICAL CONCENTRATE OR RTU CHEMICAL SOLUTION

- A compressed air-operated double diaphragm pump transfers chemical concentrate or diluted ready-to-use (RTU) chemical solution from a bulk container to any other container.
- Choice of two flow rates — up to 12 or 40 gpm when used as transfer system; lower for more viscous liquids
- Polypropylene pump with Santoprene diaphragms
- Optional Teflon diaphragm available
- *These pumping systems can also be used in Central Chemical feed Systems for delivering diluted RTU chemical solution to Lafferty Pump Fed Sanitizers, Foamers and combination Hose Drop Stations. (See Catalog 5)*

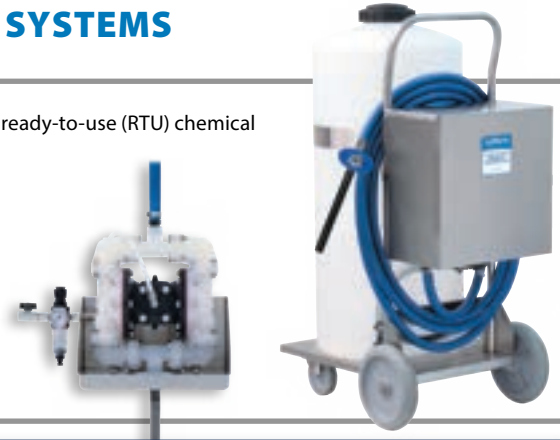

1/2" Transfer / Mini-Central Pumping System

- Complete system mounted on a heavy duty stainless steel mounting bracket.
- Portable models feature heavy duty stainless steel carts and a choice of trigger gun or ball valve.

Model #	Description
Up to 12 gallons per minute	
919050	1/2" Transfer / Mini-Central Pumping System
941940	Portable 40 Gallon Freedom XV Transfer System
710919	Teflon Diaphragm Upgrade for 1/2" Air Pump

REQUIREMENTS / SPECIFICATIONS

Compressed Air up to **16 cfm** **453.1 lpm**

Output Volume (according to intended use)

Transfer System	up to 12.0 gpm	45.4 lpm
Pumping System	up to 9.0 gpm	34.1 lpm

1" Transfer / Central Pumping System

- Complete system mounted on a heavy duty stainless steel mounting bracket.

REQUIREMENTS / SPECIFICATIONS

Compressed Air up to **35 cfm** **991 lpm**

Output Volume (according to intended use)

Transfer System	up to 40.0 gpm	151.4 lpm
Pumping System	up to 25.0 gpm	94.6 lpm

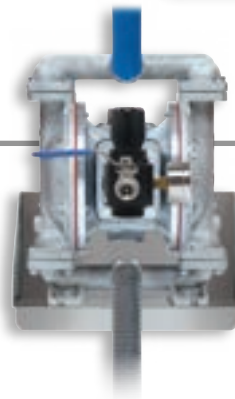

Larger capacity and custom systems available on request

Model #	Description
Up to 40 gallons per minute	
919060SS	1" Transfer / Central Pump System, Stainless Steel / Santoprene Diaphragm
710943	Teflon Diaphragm Upgrade for 1" Transfer Stainless Steel Pump

ELECTRONIC CONTROLLERS FOR TRANSFER SYSTEMS

REQUIRES: ELECTRICITY, COMPRESSED AIR @ 100 PSI

- Transfer Systems can be activated either manually or electronically.
- Lafferty offers a variety of electronic controllers for use with Chemical Transfer Systems.

Three examples of electronic controllers:

- Single Cycle
 - Recycling
 - Delay Start, Single Cycle
- Other configurations are available upon request.



See Catalog 7, Foggers & Fogging Systems for details of available electronic controllers.





Flojet Pump

1/4" AODD
Santoprene Diaphragm
Viton or Kalrez Optional

LAFFERTY CHEMICAL TRANSFER SYSTEMS use compressed air-operated double diaphragm pumps to transfer chemical concentrates or diluted ready-to-use solution from bulk containers to any other container. 1/4" AODD systems feature convenient trigger gun dispensing.

- Choice of models for handling from one to five products
- Offered in three mounting configurations: wall mount, drum mount and lock box mount
- Timed and Metering Manifold models also available

CHEMICAL TRANSFER SYSTEMS

REQUIRES: COMPRESSED AIR

- Driven entirely by compressed air
- Quick, easy set up — All system components mounted on a single, polypropylene mounting panel (except Drum Mount or Lock Box models)
- Drum Mount System straps directly to a drum or tote of chemical concentrate or ready-to-use solution
- Lock Box System is housed in a lockable, stainless steel box
- Pump(s) mounted on a unique Lafferty quick-release, stainless steel bracket (except 941601-DM).
- Discharge hose stabilizer coupling protects pump discharge outlet from abuse due to excessive pulling on the hose.
- Metering Manifold (MM) Systems use the air pump to blend and transfer two compatible chemicals concentrates or one chemical concentrate with water. Virtually any ratio can be achieved.
- Timed models include a single shot timer and require electricity

REQUIREMENTS:

Compressed Air up to 4 cfm
Flow Rate up to 4.5 gpm @ 60 PSI air

Includes

- Air regulator and air gauge
- Polypropylene air pump(s) with Santoprene diaphragm (Viton optional)
- 15 ft. suction tube and discharge hose with trigger gun for each pump
- Polypropylene mounting panel (except 941601-DM & 941601-LB)
- Stainless steel mounting bracket with polypropylene strap and integrated stainless steel hose rack (941601-DM)
- Stainless steel locking enclosure with attached mounting tabs (941601-LB)

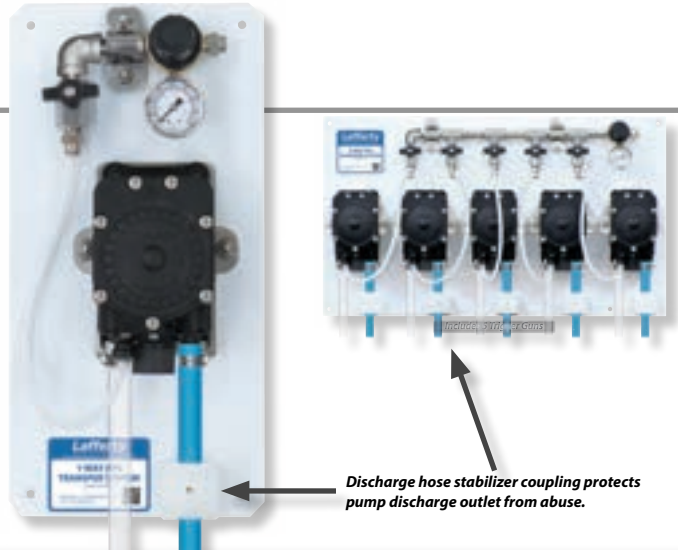

Model #	Description
941601	1-Way FPS Transfer System
941601-DM	1-Way FPS Drum Mount Transfer System
941601-LB	1-Way Lock Box Transfer System
941602	2-Way FPS Transfer System
941603	3-Way FPS Transfer System
941604	4-Way FPS Transfer System
941605	5-Way FPS Transfer System
941611	1-Way FPS MM Transfer System
941621	1-Way FPS Timed Transfer System

OPTIONS:

Upgrades for FPS Transfer Systems (at time of purchase only)

9416100-ATEX	Upgrade: Kalrez (ATEX) Air Pump + EPDM Hoses*
9416100-KT	Upgrade: Kalrez Air Pump and Viton Trigger Gun
9416100-VT	Upgrade: Viton Air Pump and Viton Trigger Gun
9416100-X	SS BV Upgrade for Transfer Station

***941600-ATEX — Upgrade for Solvent/Alcohol Applications**

- Customized to include EPDM hoses and an ATEX-approved pump with Kalrez (FFKM) diaphragms, suitable for solvent/alcohol applications and any applications requiring ATEX approval. (For more Solvent / Acid applicators, see Catalog 8)

Includes: • Polypropylene mounting panel • Air regulator and air gauge; • FloJet AODD pump with Kalrez diaphragms and Viton o-ring seals (ATEX approved); Stainless steel quick release bracket; 15' EPDM chemical pickup tube and discharge hose; • Polypropylene trigger gun with stainless steel and EPDM internal components

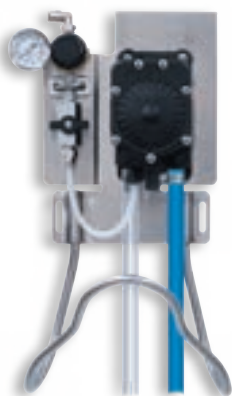

941601-DM



941601-LB



CHEMICAL MANAGEMENT



LAFFERTY PROPORTIONAL DISPENSING SYSTEMS are water-driven systems that dilute chemical concentrates to required ratios and dispense, on demand, pressurized ready-to-use (RTU) chemical solution that can supply a holding tank, a chemical dispensing network — such as a sprinkler or irrigation system in a nursery, or animal/chicken watering troughs for medication dispensing — or chemical foam and spray applicator(s) at a distance.* (See note below.)

The non-electric proportioning injectors maintain the selected dilution ratio at any water pressure within the standard operating range.

WATER DRIVEN PROPORTIONAL DISPENSING SYSTEM — On Demand

REQUIRES: 40 TO 100 PSI WATER

- Water driven, non-electrical, proportional dispensing system dilutes chemical concentrates to required ratios and dispense pressurized RTU chemical solution
- Polypropylene or PVDF construction
- Complete system mounted on a panel, or within a lockable stainless steel enclosure, for convenience and ease of installation
- Choice of fully adjustable dilution ratio ranges, from 1:3000 to 1:50
- Choice of seals for chemical compatibility
- Kalrez seals available for Peracetic Acid

* NOTE: When considering using a Water Driven Proportional Dispensing System as a Central Chemical Feed System for pump fed foamers, sanitizers or combination hose drop stations, it is important to know that you have sufficient water pressure to run the system. The pressure drop across the proportioner can be up to 15 PSI. When this is combined with the friction loss in the header piping system, the final fluid pressure may be less than the 35 PSI required at each pump fed foamer or sprayer.

Other configurations and custom systems available on request

Full range of flow rates and dilution ranges available, from 3.5 gpm to 100 gpm.

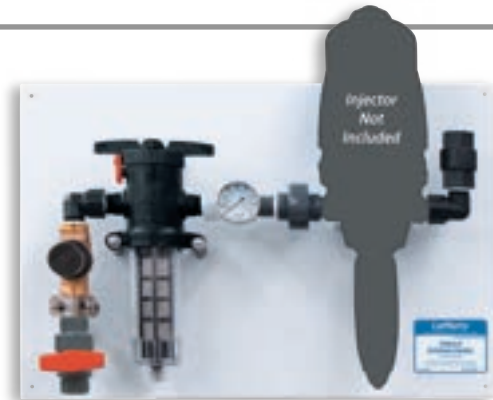

Model #	Description
909900	Single Dosing Panel (Injector Sold Separately)
Dosatron Proportioning Pumps	
Up to 14 Gallons/Minute	
D14MZ2VFII	14 GPM dispenser, 1:500 to 1:50
D14MZ3000VFII	14 GPM dispenser, 1:3000 to 1:300



Viton or EPDM

LAFFERTY DRUM STICKS™ AND TOTE STICKS™ are chemical pick-up assemblies for use with pump-operated or venturi systems to draw chemical concentrates or diluted chemical solution directly from a drum, tote or holding tank.

Choice of seal material for optimum chemical resistance.

Choice of lengths with custom lengths available.

DRUM STICK / TOTE STICK

- Chemical/acid resistant polypropylene construction
- Connects to chemical pick-up tubes fitted to any venturi applicator or chemical pumping system
- Drum Bung Adaptor, machined to fit either coarse or fine-threaded bung holes, and Tote Stick Cover, for larger openings on totes and other bulk containers, keep trash out of chemical and allow easy depth adjustment of the Drum or Tote Stick.
- Rigid pipe overcomes problems common with flexible tubing
- Hastelloy strainer easily accessible for cleaning
- Choice of Viton or EPDM seals

SPECIFICATIONS

Polypropylene extension pipe

ID	3/4 in.	19.1 mm
Lengths:	Pipe Length	Inside Drum/Tote
33" Drum Stick	33 in. / 0.83 m	35 in. / 0.89 m
48" Drum Stick	48 in. / 1.22 m	50 in. / 1.27 m
54" Drum Stick	54 in. / 1.37 m	56 in. / 1.42 m
33" Tote Stick	33 in. / 0.8 m	36 in. / 0.91 m
48" Tote Stick	48 in. / 1.22 m	51 in. / 1.29 m
54" Tote Stick	54 in. / 1.37 m	57 in. / 1.45 m

Includes

- Machined polypropylene Drum Bung Adaptor with coarse and fine threads or 11" x 11" polypropylene Tote Stick Cover
- Four polypropylene hose barbs:

1/4 in.	6.3 mm
3/8 in.	9.5 mm
1/2 in.	12.7 mm
3/4 in.	19.0 mm
- Polypropylene chemical check valve
- Hastelloy chemical strainer

Model #	Description
491643	Drum Stick, 33" (Viton seals)
491643-E	Drum Stick, 33" (EPDM seals)
491644	4-Way Drum Stick, 33" (Viton seals)*
491644-E	4-Way Drum Stick, 33" (EPDM seals)*
491648	Drum Stick, 48" (Viton seals)
491648-E	Drum Stick, 48" (EPDM seals)
491649	4-Way Drum Stick, 48" (Viton seals)*
491645	Drum Stick, 54" (Viton seals)
491645-E	Drum Stick, 54" (EPDM seals)
491653	Tote Stick, 33" (Viton seals)
494653-E	Tote Stick, 33" (EPDM seals)
491654	Tote Stick, 48" (Viton seals)
491654-E	Tote Stick, 48" (EPDM seals)
491656	Tote Stick, 54" (Viton seals)
491656-E	Tote Stick, 54" (EPDM seals)

Custom lengths available on request

SAFE FLOW LID™ FOR 1 GALLON JUGS AND 5 GALLON PAILS

JUG LID WITH SUCTION TUBE:

- Machined polypropylene lid, threaded to fit 1 gallon jugs (see page 14 for models that fit 5 gallon jugs/pails)
- Safe and Convenient — Prevents chemical splashing; Allows quick replacement of concentrate
- Incorporated barb attaches directly to suction tube of Lafferty Hose End Airless Sprayer or Foamer
- Includes attached suction tube



Model #	Description
709101	Safe Flow Lids™ for 1 Gallon Jugs and 5 Gallon Pails

CHEMICAL MANAGEMENT



CHEMICAL TANKS AND ACCESSORIES — Lafferty offers four sizes of tanks for use with Lafferty Chemical Management Systems or for auxiliary chemical storage.

All tanks are made of high density polyethylene for chemical resistance and material durability.

CHEMICAL/WATER TANKS



Model #	Description
709105	5-Gallon Pail (HDPE) with Pail Stick™
709105-SQ	5-Gallon Pail (HDPE), Square, with Pail Stick™
709106-LID	70mm Lid For 5 Gallon Pail (replacement)
709120	Tank, 20 Gallon, HDPE (color options available)
709140	Tank, 40 Gallon, HDPE
709160	Tank, 60 Gallon, HDPE

Contact us for details.

CHEMICAL DISPENSING ACCESSORIES:

SAFE FLOW™ JUG OR PAIL LIDS AND PAIL STICKS

- Safe and Convenient — Prevents splashing, reduces odor, and allows for quick replacement of chemical concentrate.
- **Jug / Pail Lids:** Machined polypropylene lids threaded to fit 1 gallon jugs and the pull-up spout of many 5 gallon pails.
- **Jug Lid** includes 1' of suction tubing. (Model 709101-R fits Rieke FLEXSPOUT® closures.) **Slip Stick** includes a sliding Jug Lid and fits containers up to 21" deep.
- All models shown include a hose barb that attaches directly to any ¼" suction tube of a Lafferty chemical applicator or dispenser.
- **Pail Sticks:** Polypropylene sticks with sliding collars, threaded to fit ¾" container lid knockouts.
- **Model 709105** includes a 16" Pail Stick and 5 gallon pail with lid.



709101 (various models)
1 Gallon Safe Flow Lid w/
Flexible Tube & Strainer

491610 - 5 Gallon
Safe Flow Lid w/ Rigid
Tube & Strainer

709105 - 5 Gallon Pail
with Suction Stem

Safe Flow Pail Sticks
491617 - 16" (above, left)
491622 - 21" (above, right)

BACKFLOW PREVENTERS

- Designed for use on non-health-hazard, continuous pressure, point-of-use applications for protection against back siphonage and back pressure
- When installed upstream of a water-driven foamer or sprayer this part will prevent chemical solution and/or compressed air from backing up into the water source in the event of reverse suction (power failure, improper operation, failure to close inlet ball valves, etc.)
- Discharge vent can be plumbed to direct the discharge to an appropriate drainage area.
- May be mounted horizontally or vertically

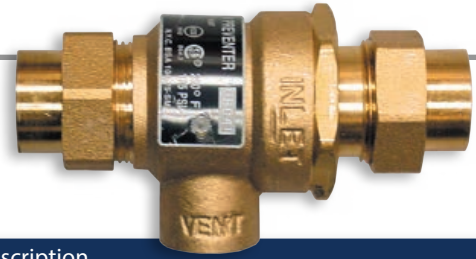

Model #	Description
270298	1/2" (Watts 9DM2) Backflow Preventer
270299	3/4" (Watts 9DM3) Backflow Preventer

WATER PRESSURE/FLOW TEST KIT

- Provides quick confirmation of available water pressure and water flow at the equipment water inlet
- Connects to standard male garden hose fitting
- Use to determine equipment needed for existing setup or a new facility
- Also for use mounted in line with installed equipment to determine operational water pressure
- Troubleshoot existing setup
- Features three flow restrictors for testing standard flow, medium flow and high flow applicators



Includes four metering plugs



Model #	Description
336340	Water Pressure/Flow Test Kit

REQUIREMENTS / SPECIFICATIONS

Water Pressure Max.	160 PSI	11 bar
Water Flow Rate	@ 40 PSI	@ 2.8 bar
Small restrictor	1 gpm	3.8 lpm
Medium restrictor	4 gpm	15.1 lpm
Large restrictor	9 gpm	34.1 lpm

METERING TIP DRIVER*

- Simply the best and easiest way to install or change metering tips across the entire Lafferty venturi product lineup.



Model #	Description
443790	Metering Tip Driver

*One Metering Tip Driver is included in each pack of metering tips enclosed with new venturi applicator orders.

LAFFERTY QUICK RELEASE BRACKET FOR FLOJET G57 AIR PUMP

- Designed by Lafferty specifically for use with the Flojet G57 air pump
- Allows easy removal and replacement of the air pump without tools
- Included as standard component in most Lafferty systems with a Flojet G57 Air pump (for example, FPS Transfer Systems; Liberty and Liberty LF foamers and sprayers).

Adds a quick-release capability to any Flojet G57 installation.

Model #	Description
226095BRKT	Flojet Pump Quick Release Bracket, SS

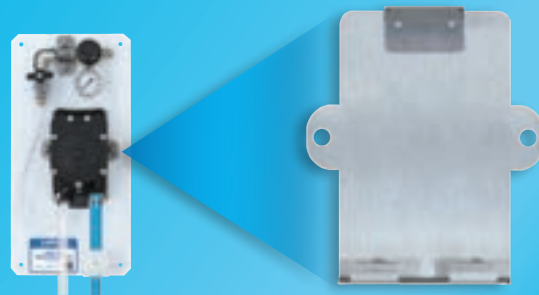

JUG RACKS & HOSE RACKS

Lafferty Stainless Steel Jug Racks can be used for holding containers of chemical concentrate to be used by a Lafferty Mixing Station or for holding empty containers while being filled by a Lafferty Mixing Station or Chemical Transfer System.

Stainless steel hose straps and hose racks can be used with any Mixing Station or Transfer System equipped with a longer discharge hose or for storing other hoses used in the chemical handling area.

STAINLESS STEEL JUG RACKS

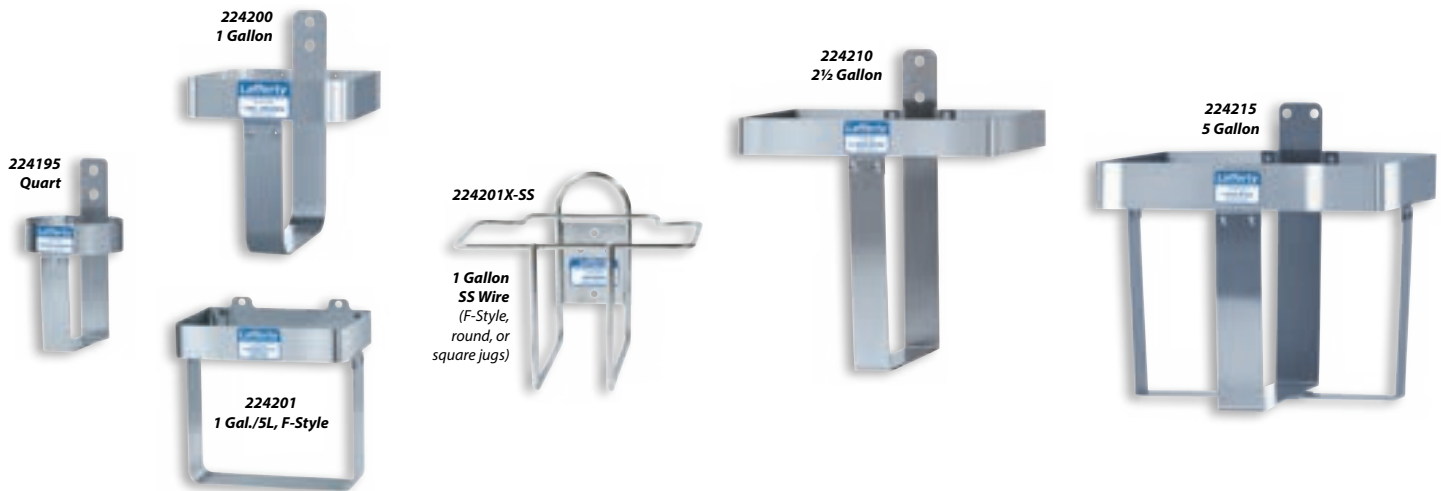

DIMENSIONS

Model #		Diameter or Width x Depth	
224195	Quart	3 7/8 in. ID	9.8 cm ID
224200	1 Gal. Round/Sq.	6 1/2 x 6 3/8 in.	16.5 x 16.2 cm
224200-L	1 Gal. Rnd./Sq., Locking	6 1/2 x 6 3/8 in.	16.5 x 16.2 cm
224201	1 Gal./5L R'tangle, F-Style	7 5/8 x 5 7/8 in.	19.4 x 14.9 cm
224201X-SS	1 Gal. Wire, Rnd./Sq./F	8 x 6 3/8 in.	22.9 x 22.9 cm
224210	2 1/2 Gal.	10 5/8 x 8 1/2 in.	27.0 x 21.6 cm
224214	5 Gal. Rnd./Sq., Locking	13 x 12 6/8 in.	33.0 x 32.4 cm
224215	5 Gal. Rnd./Sq.	13 x 12 6/8 in.	33.0 x 32.4 cm

Model #	Description
224195	Jug Rack, SS, 1 Quart
224200	Jug Rack, SS, 1 Gallon Round/Square
224200-L	Jug Rack, SS, 1 Gallon Round/Square, Locking
224201	Jug Rack, SS, 1 Gallon/5 Litre Rectangular, F-Style
224201X-SS	Jug Rack, 1 Gallon SS Wire (Round/Square/F-Style)
224210	Jug Rack, SS, 2 1/2 Gallon
224214	Jug Rack, SS, 5 Gallon Round/Square, Locking
224215	Jug Rack, SS, 5 Gallon Round/Square

LOCKABLE

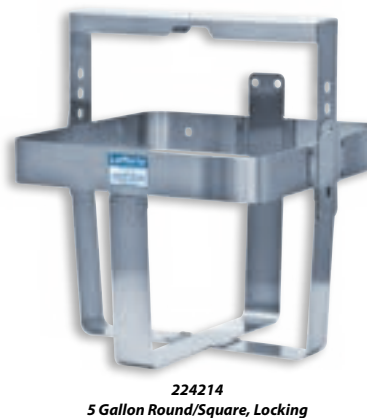

STAINLESS STEEL HOSE RACKS

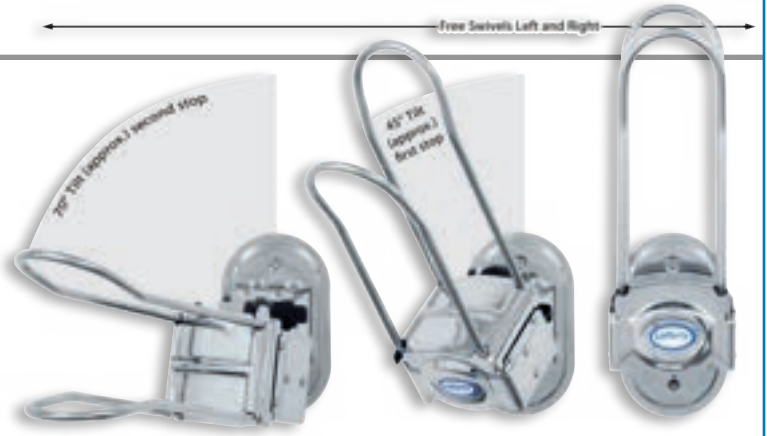

HOSE CARRYING CAPACITY

Model #		Inside Diameter x Length	
224140	Strap	1/2 in. ID up to 75 ft. (+/-)	12.7 mm ID x 22.9 m (+/-)
224142	Strap, L	3/4 in. ID up to 75 ft. (+/-)	19.1 mm ID x 22.9 m (+/-)
224145	Small	3/4 in. ID up to 50 ft. (+/-)	19.1 mm ID x 15.4 m (+/-)
224150	Large	1 in. ID up to 75 ft. (+/-)	25.4 mm x 22.9 m (+/-)
224160	Tilt	3/4 in. ID up to 100 ft. (+/-)	19.1 mm ID x 30.5+ m (+/-)

Model #	Description
224140	Hose Strap, SS
224142	Hose Strap, SS, Large
224145	Hose Rack, SS, Small
224150	Hose Rack, SS, Large
224160	Hose Rack, SS, Large Tilt

STAINLESS STEEL HOSE REELS

- This retractable reel features a full-port swivel that allows unrestricted foam output. Other reels may have ports with narrowed openings through the swivel, which compresses the foam, resulting in watery, inferior foam output.
- Use with confidence with a wide range of Lafferty sprayers/sanitizers and foamers that require 3/8" or 1/2" ID hose

Features

- Stainless steel construction and a heavy-duty steel base ensure strength, safety, corrosion resistance, and durability
- Electro-Polished Stainless Steel finish
- Non-Corrosive Stainless Steel Fluid Path Featuring Stainless Steel Swivel
- Auto Rewind via a non-corrosive stainless steel cartridge-style spring motor easily wraps, stores and protects hose
- Adjustable hose stop prevents full hose retraction and allows for quick, easy access to hose-end tools
- Guide arm adjusts to wall, floor & overhead positions
- Pinch-proof, four-way, guide-arm rollers allow the hose to be pulled from the reel in any direction

REQUIREMENTS / SPECIFICATIONS

Water Pressure	up to	150 PSI	10.3 bar
Discharge Hose ID	either	1/2 in.	12.7 mm
		3/4 in.	19.1 mm
Water Pressure	up to	300 PSI	20.7 bar
	up to	2500 PSI	172.4 bar
Discharge Hose ID	either	3/8 in.	9.5 mm
		1/2 in.	12.7 mm

Includes:

- 6' Lafferty-specified jumper hose (assures compatibility with Lafferty foamers and spray applicators)
- Heavy Gauge Steel/Stainless Steel Base & Support Post
- Stainless Steel Rollers
- Factory-Matched Cartridge-Style Spring Motor

- Multi-Position Lock Ratchet Secures Hose At Desired Length
- Rolled Edges & Ribbed Discs Provide Strength & Safety
- Leading 2-Year Manufacturer's Limited Warranty

† Allow six weeks production time. Discharge hose and applicator wand not included.

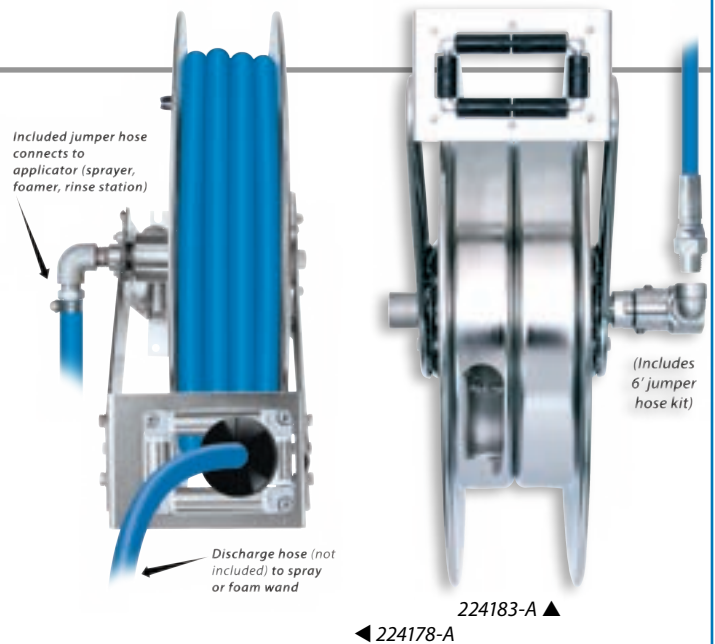

Model #	Description
224177-A	Hose Reel, SS, 1/2" x 50', 150 PSI, w/ Jumper Hose Kit
224178-A	Hose Reel, SS, 3/4" x 50', 150 PSI, w/ Jumper Hose Kit
224183-A	Hose Reel, SS, 3/8" x 75', 300 PSI, w/ Jumper Hose Kit
224186-A	Hose Reel, SS, 1/2" x 75', 300 PSI, w/ Jumper Hose Kit
High Pressure	
224173-A	Hose Reel, SS, 3/8" x 50', 2500 PSI, w/ Jumper Hose Kit
224176-A	Hose Reel, SS, 1/2" x 50', 2500 PSI, w/ Jumper Hose Kit

NOTES:



MIXING STATIONS



LAFFERTY MIXING STATIONS OFFER FLOW RATES SUITED TO FILLING ANY SIZE CONTAINER.

- BOTTLE FILL • LOW FLOW • HIGH FLOW • HIGH VOLUME

NOTES:

LAFFERTY CATALOG SERIES

• Food & Beverage Processing • Pharmaceutical • Agriculture • General Industrial Applications



1 • Venturi Systems – City Water Pressure

2 • Venturi Systems – Boosted Pressure

3 • Venturi Systems – High Pressure

4 • Compressed Air Operated Systems

5 • Pump Fed Sanitizers, Foamers & Hose Drop Stations

6 • Entryway, Drain & Hand Sanitizing Systems

7 • Foggers and Fogging Systems

Special Applications

8 • Asphalt Release, Acid / Corrosive & Solvent Systems

9 • Chemical Management Systems

10 • Vehicle Wash & Detailing Systems

11 • JanSan / Commercial / Residential Systems

12 • Supermarket / Deli / Small Area Cleaning Systems

