

Spence Types K1 and K4 Control Valve



Figure 1. Type K1 Control Valve

Introduction

Types K1 and K4 Control Valves are designed for economical control of steam, water, gas and process applications in typical institutional, commercial and industrial processes. Types K1 and K4 are available with either a direct or reverse acting actuator that meets most application requirements.

Principle of Operation

The Types K1 and K4 Control Valves are flow to open, globe style, pneumatic diaphragm control valves. The pneumatic actuator can be arranged to operate with either air to close or air to open control.

A controller sensing the controlled variable provides a signal to the actuator of the control valve to obtain the desired control.

Types K1 and K4

Specifications

This section lists the specifications for the Types K1 and K4 control valves. Factory specifications are stamped on the nameplate fastened on the control valve at the factory.

Control Valve Types

Type K1: Single-seat, bronze with union ends and pneumatic actuator

Type K4: Single-seat, flanged, cast iron and pneumatic actuator

Control Valve Sizes

Type K1: NPS 1/2, 3/4, 1, 1-1/4, 1-1/2 and 2 / DN 15, 20, 25, 32, 40 and 50

Type K4: NPS 2-1/2, 3 and 4 / DN 65, 80 and 100

Pressure and Temperature Chart⁽¹⁾

See Figure 2

End Connection Styles

NPT, CL125 and CL250

Maximum Rated Flow Coefficient, C_v

NPS 1/2 / DN 15: 5.2

NPS 3/4 / DN 20: 7.0

NPS 1 / DN 25: 11

NPS 1-1/4 / DN 32: 20

NPS 1-1/2 / DN 40: 25

NPS 2 / DN 50: 30

NPS 2-1/2 / DN 65: 71

NPS 3 / DN 80: 94

NPS 4 / DN 100: 146

Construction Materials

Body: Bronze or Cast iron

Seat: Stainless steel

Bonnet: Ductile iron

Plug, Stem and Stem Assembly: Stainless steel

Stem Guide: Stainless steel or Brass

Actuator Casing: Steel

Actuator Spring: Steel wire

Diaphragm: Nitrile (NBR)/Polyester

Yoke: Ductile iron

Options

36 or 60 sq. in. / 0.02 or 0.04 sqm actuators

Electric Actuator

Applicable Codes

Meets or exceeds ANSI B16.15 Class 250 or

ANSI B16.1 Class 125

ANSI/FCI 70-2 Class IV Seat Leakage

Approximate Weight

See Table 1

1. The pressure/temperature limits in this Bulletin and any applicable standard or code limitation should not be exceeded.

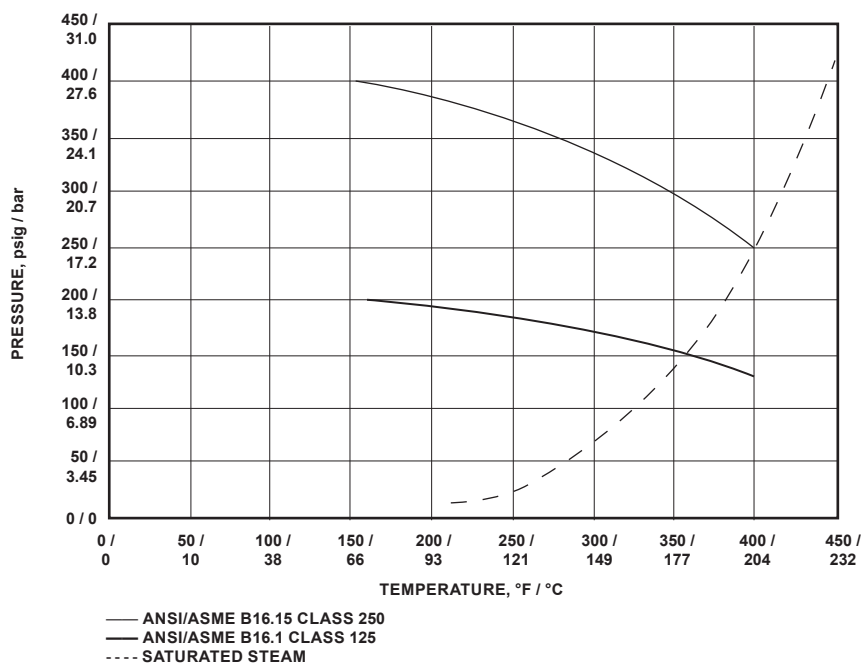

Figure 2. Types K1 and K4 Pressure and Temperature Chart

Types K1 and K4

Table 1. Types K1 and K4 Shutoff Table

VALVE SIZE	ORIFICE	ACT.	BENCH RANGE	ACTUATOR CODE	REVERSE SHUTOFF ⁽¹⁾			BENCH RANGE	ACTUATOR CODE	DIRECT SHUTOFF		
					3 to 15 psi	0 to 20 psi ⁽²⁾	0 to 30 psi ⁽³⁾			3 to 15 psi	0 to 20 psi ⁽²⁾	0 to 30 psi ⁽³⁾
NPS 1/2 / DN 15	A, C, E	36	6 to 15	RA	400	400	----	3 to 12	DA	400	400	----
	B	36	6 to 15	RA	400	400	----	3 to 12	DA	300	400	----
			----	----	----	----	----	3 to 9	DB	400	400	----
T	36	6 to 15	RA	300	400	----	3 to 9	DB	400	400	----	
NPS 3/4 / DN 20	T	36	6 to 15	RA	100	300	----	3 to 9	DB	250	400	----
			9 to 15	RR	225	350	----	----	----	----	----	----
			12 to 15	RC	300	400	----	----	----	----	----	----
		60	12 to 15	RC	400	400	----	3 to 7	DG	400	400	----
NPS 1 / DN 25	T	36	9 to 15	RB	150	250	----	3 to 9	DB	100	200	----
			12 to 15	RC	250	400	----	----	----	----	----	----
			13 to 15	RE	400	400	----	----	----	----	----	----
		60	----	----	----	----	----	3 to 7	DG	400	400	----
NPS 1-1/4 / DN 32	T	36	9 to 15	RB	150	175	----	3 to 9	DR	150	250	----
			12 to 15	RC	200	250	----	----	----	----	----	----
			13 to 15	RE	250	275	----	----	----	----	----	----
		60	12 to 15	RG	300	400	----	3 to 7	DG	300	400	----
			13 to 15	RH	400	400	----	----	----	----	----	----
NPS 1-1/2 / DN 40	T	36	12 to 15	RC	150	225	----	----	----	----	----	----
			13 to 15	RE	200	250	----	----	----	----	----	----
		60	12 to 15	RG	225	275	----	3 to 7	DG	200	400	----
			13 to 15	RH	275	300	----	----	----	----	----	----
NPS 2 / DN 50	T	36	12 to 15	RC	50	75	----	----	----	----	----	----
			13 to 15	RE	75	100	----	----	----	----	----	----
		60	12 to 15	RG	125	200	----	3 to 7	DG	100	300	----
			13 to 15	RH	175	250	----	----	----	----	----	----
NPS 2-1/2 / DN 65	T	60	10 to 15	RH	75	----	100	3 to 8	DH	70	----	200
			12 to 15	RQ	125	----	125	3 to 8	DH	70	----	200
			22 to 30	RT	----	----	125	3 to 8	DH	70	----	200
NPS 3 / DN 80	T	60	10 to 15	RH	40	----	60	3 to 8	DH	40	----	100
			12 to 15	RQ	60	----	80	3 to 8	DH	40	----	100
			22 to 30	RT	----	----	110	3 to 8	DH	40	----	100
NPS 4 / DN 100	T	60	12 to 15	RQ	20	----	32	3 to 8	DH	10	----	25
			22 to 30	RT	----	----	50	3 to 8	DH	10	----	25

Note: Reverse Acting - Fail Closed/Air to Open (FC/ATO)

Direct Acting - Fail Open/Air to Close (FO/ATC)

1. Shutoff pressures are in conformance with ANSI/FCI 70-2 Class IV

2. Based on 20 psi air supply.

3. Based on 30 psi air supply.

Types K1 and K4

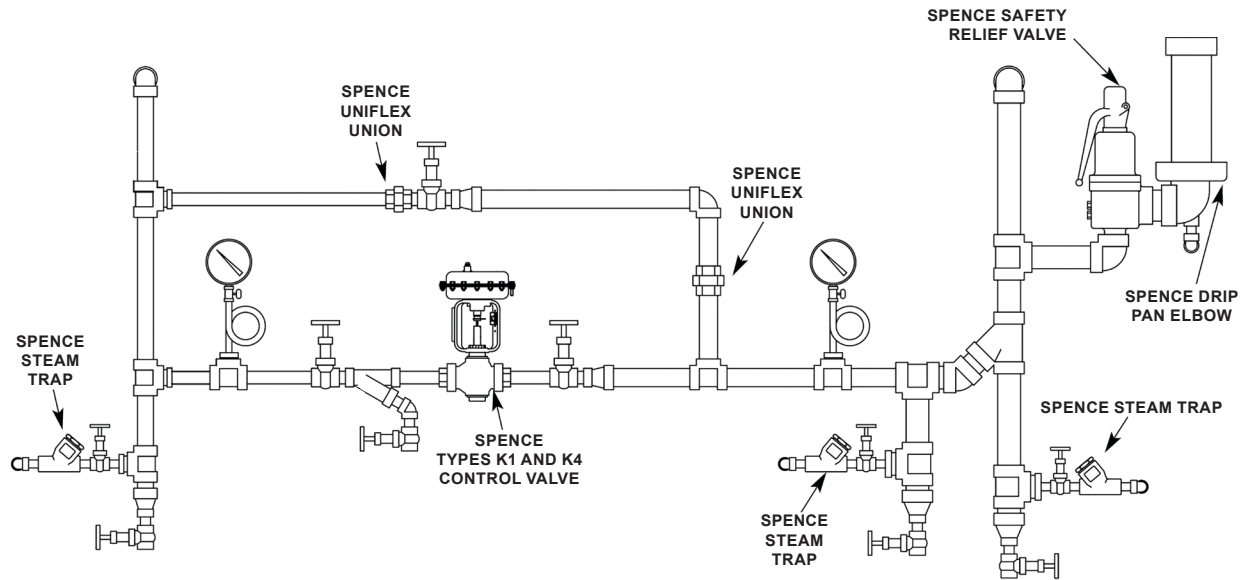

Figure 3. Types K1 and K4 Control Valve Recommended Installation for Steam Application

Table 2. Types K1 and K4 Flow Coefficient

PERCENT OF TRAVEL				5	10	20	30	40	50	60	70	80	90	100
Valve Size		Travel	Orifice	C _v										
NPS	DN													
1/2	15	1/4	C	0.1	0.2	0.3	0.36	0.41	0.46	0.51	0.56	0.6	0.65	0.7
			E	0.3	0.5	0.7	0.9	1.1	1.3	1.5	1.7	1.9	2	2.1
			A	0.3	0.6	1.2	1.7	2.2	2.6	2.9	3.1	3.2	3.25	3.3
			B	0.15	0.25	0.65	1.5	2.7	3.3	3.7	3.9	4.1	4.2	4.3
3/4	20	5/16	T	0.7	1.3	2.4	3.3	4.2	4.9	5.5	6.0	6.4	6.8	7.0
1	25	1/4	T	0.7	1.3	2.4	3.8	5.5	7.4	9.0	10.0	10.6	10.9	11.0
1-1/4	32	5/16	T	0.8	1.7	4.0	6.5	9.3	12.6	15.3	17.0	18.1	19.1	20.0
1-1/2	40	5/16	T	1.0	2.0	4.5	7.2	9.9	12.4	15.2	18.2	20.9	23.4	25.0
2	50	5/16	T	1.0	2.0	4.5	7.4	10.6	15.1	18.8	22.8	26.1	28.3	30.0
2-1/2	65	3/4	T	5	11	23	36	46	53	59	62.5	65.7	68	71
3	80	3/4	T	5	11	30	47	61	72	79	85	90	92	94
4	100	3/4	T	12	23	46	69	89	104	116	127	134	140	146

Installation

- Locate the valve in a straight run of horizontal pipe as shown in Figure 3. Mount the valve with the actuator in the upright position. Allow room for removal of the actuator.
- Prevent pipeline hammering in compressible fluid service by providing proper drainage before and after the valve.
- Avoid damaging effects of scale and dirt in pipelines by using a strainer.
- A three-valve by-pass to facilitate inspection and maintenance without interrupting service is recommended.
- To eliminate excessive noise with steam and other compressible fluids, enlarge the delivery pipe size to allow a reasonable flow velocity at the reduced pressure. A concentric transition is recommended.
- If possible, avoid sharp turns close to the valve.
- Install upstream and downstream pressure gauges to indicate performance.
- If the rating of the delivery system or connected equipment is less than the initial pressure, provide a safety relief valve.

Types K1 and K4

Table 3. Types K1 and K4 Saturated Steam Capacity in lbs/hr

PRESSURE, psi		VALVE SIZE AND PORT, NPS												
P1	P2	1/2 C	1/2 E	1/2 A	1/2 B	1/2 T	3/4	1	1-1/4	1-1/2	2	2-1/2	3	4
10	5	22	65	102	133	161	217	341	620	775	930	2237	2962	4601
	0	27	81	128	166	201	270	425	773	966	1159	2846	3768	5853
15	10	24	72	114	148	179	241	379	689	861	1033	2477	3280	5094
	5	31	92	145	189	229	308	484	880	1099	1319	3216	4257	6613
20	0	34	101	159	207	250	337	529	962	1202	1443	3586	4748	7374
	15	26	79	124	161	195	262	412	750	937	1125	2692	3565	5537
	10	34	102	161	209	253	341	536	974	1217	1461	3543	4691	7286
30	0	40	119	187	243	294	396	623	1132	1416	1699	4262	5643	8765
	25	30	90	142	184	223	300	472	858	1072	1287	3072	4067	6316
	15	46	137	215	280	338	455	715	1301	1626	1951	4755	6295	9778
40	0	51	152	239	312	377	507	797	1450	1812	2174	5525	7315	11,362
	25	52	156	245	319	385	519	815	1482	1852	2223	5384	7128	11,071
	15	59	178	280	365	442	595	935	1699	2124	2549	6297	8337	12,948
50	0	62	185	290	378	457	615	967	1758	2198	2637	6724	8903	13,827
	35	57	172	271	353	427	575	903	1643	2053	2464	5943	7869	12,222
	30	63	190	299	389	470	633	995	1809	2262	2714	6596	8732	13,563
	25	67	202	318	414	501	674	1059	1925	2406	2888	7076	9368	14,550
60	2 to 0	72	217	341	444	537	723	1136	2066	2582	3099	7905	10,466	16,256
	45	63	188	295	384	464	625	982	1786	2232	2679	6444	8531	13,250
	40	69	208	327	426	515	693	1090	1981	2477	2972	7194	9524	14,792
	35	74	223	351	457	552	744	1169	2125	2656	3187	7767	10,282	15,971
75	4 to 0	83	249	391	509	616	829	1303	2370	2962	3555	9067	12,005	18,645
	55	77	232	365	476	575	774	1216	2212	2765	3318	7996	10,587	16,443
	50	84	251	395	514	622	837	1315	2391	2989	3587	8690	11,505	17,870
	45	89	266	417	544	658	885	1391	2530	3162	3795	9246	12,241	19,013
100	8 to 0	99	296	466	607	734	988	1552	2822	3527	4233	10,797	14,294	22,202
	75	97	291	457	596	721	970	1525	2773	3466	4159	10,020	13,266	20,604
	60	113	340	534	696	841	1133	1780	3236	4045	4854	11,845	15,683	24,358
125	15 to 0	125	375	589	767	927	1249	1962	3567	4459	5351	13,649	18,071	28,068
	100	109	326	512	667	806	1086	1706	3102	3877	4652	11,169	14,787	22,968
	75	138	413	649	845	1022	1376	2163	3933	4916	5899	14,409	19,077	29,630
150	21 to 0	151	452	710	925	1119	1507	2367	4304	5381	6457	16,470	21,806	33,869
	125	119	356	560	730	882	1188	1866	3394	4242	5090	12,192	16,142	25,071
	100	153	460	723	943	1140	1535	2412	4385	5481	6577	15,975	21,150	32,850
175	28 to 0	176	529	831	1082	1309	1762	2769	5035	6293	7552	19,264	25,505	39,614
	150	128	384	604	787	951	1281	2013	3659	4574	5489	13,124	17,376	26,988
	125	168	503	791	1030	1246	1677	2635	4791	5989	7187	17,388	23,021	35,755
	100	189	567	891	1161	1403	1889	2969	5398	6747	8097	19,859	26,293	40,838
200	35 to 0	202	605	951	1239	1498	2016	3168	5761	7201	8641	22,031	29,168	45,304
	150	181	542	852	1110	1342	1806	2839	5161	6452	7742	18,677	24,728	38,407
	125	206	618	971	1265	1529	2059	3235	5882	7353	8823	21,533	28,509	44,279
225	41 to 0	227	681	1069	1393	1685	2268	3565	6481	8101	9722	24,799	32,833	50,996
	175	193	578	908	1183	1430	1925	3025	5500	6875	8250	----	----	----
	150	221	664	1043	1359	1644	2213	3478	6323	7904	9485	----	----	----
250	48 to 0	252	755	1187	1547	1870	2518	3956	7194	8992	10,790	----	----	----
	200	204	611	960	1251	1512	2036	3199	5817	7271	8725	----	----	----
	150	256	769	1208	1574	1904	2563	4027	7322	9153	10,984	----	----	----
	100	275	825	1297	1690	2044	2752	4324	7862	9827	11,792	----	----	----
	54 to 0	277	830	1304	1699	2055	2766	4346	7902	9878	11,854	----	----	----

Note: It is recommended to keep valve outlet velocity below 30,000 ft./min.
Capacities are based on maximum C_v.

Types K1 and K4

Table 4. Types K1 and K4 Saturated Steam Capacity in kg/hr

PRESSURE, bar		VALVE SIZE AND PORT, DN												
P1	P2	15 C	15 E	15 A	15 B	15 T	20	25	32	40	50	65	80	100
0.7	0.3	10	31	49	64	78	104	164	298	373	447	1079	1429	2220
	0.2	11	34	53	69	84	113	177	322	402	483	1171	1551	2409
1	0.7	10	31	48	63	76	102	161	292	365	438	1049	1389	2157
	0.5	12	37	59	76	92	125	196	356	445	534	1289	1707	2651
1.5	0.3	14	42	65	85	103	139	218	396	495	594	1448	1918	2978
	1	14	43	67	87	106	142	224	407	508	610	1467	1942	3017
	0.7	17	50	79	103	124	167	263	479	598	718	1746	2312	3591
2	0.5	18	53	84	109	132	178	280	508	635	762	1870	2476	3846
	1.5	16	47	74	97	117	157	247	449	562	674	1616	2139	3323
	1.2	19	56	88	115	139	188	295	536	670	804	1945	2575	3999
3	1	20	60	95	124	149	201	316	575	719	862	2100	2781	4319
	2	24	73	114	149	180	242	381	692	865	1038	2508	3321	5158
	1.0	29	87	137	179	216	291	457	832	1040	1248	3098	4102	6371
3.5	0	32	97	152	198	239	322	506	920	1149	1379	3264	4322	6713
	3.0	20	59	92	120	145	195	307	558	698	838	2000	2647	4112
	2.0	30	89	140	182	221	297	466	848	1060	1272	3099	4103	6373
	1.0	33	99	155	202	245	329	518	941	1176	1412	3531	4675	7261
4	1 to 0	36	108	170	222	268	361	567	1031	1289	1547	3661	4847	7528
	3.0	28	83	130	169	204	275	432	786	983	1179	2836	3755	5832
	2.0	34	103	162	211	255	344	540	982	1228	1473	3615	4786	7433
	1.0	37	110	172	224	271	365	574	1044	1305	1566	3942	5219	8105
5	3 to 0	39	118	186	242	293	394	620	1126	1408	1690	4000	5296	8225
	4.0	30	91	144	187	226	305	479	870	1088	1306	3131	4145	6438
	3.0	39	117	184	239	290	390	612	1113	1392	1670	4069	5387	8367
	2.0	43	128	201	262	317	427	671	1220	1525	1830	4544	6016	9344
7	6 to 0	47	140	220	287	347	467	734	1334	1667	2001	4757	6299	9783
	5.0	47	140	221	288	348	468	736	1338	1672	2007	4848	6419	9970
	3.0	56	169	265	346	418	563	884	1607	2009	2411	5987	7926	12,311
9	1.0 to 0	62	187	293	382	462	622	978	1778	2222	2667	6311	8356	12,978
	7.0	53	160	252	328	397	534	839	1526	1907	2289	5505	7289	11,321
	5.0	67	200	314	410	496	667	1048	1906	2382	2859	7015	9288	14,425
10	1.6 to 0	77	230	361	470	569	765	1203	2187	2733	3280	7762	10,277	15,962
	8.0	56	168	265	345	417	562	882	1605	2006	2407	5780	7652	11,885
	5.0	75	224	353	459	556	748	1175	2137	2671	3205	7916	10,480	16,277
12	1.8 to 0	84	251	395	515	623	838	1317	2395	2994	3592	8502	11,256	17,483
	10.0	62	185	291	379	458	616	968	1761	2201	2641	6327	8376	13,009
	7.0	85	254	399	520	629	846	1330	2418	3023	3627	8886	11,764	18,272
	5.0	90	270	425	553	669	900	1415	2573	3216	3859	9633	12,753	19,808
14	2.4 to 0	98	294	462	602	728	979	1539	2798	3498	4197	9939	13,158	20,438
	10.0	87	261	410	535	647	871	1368	2488	3110	3732	-----	-----	-----
	5.0	104	312	491	640	774	1041	1636	2975	3719	4463	-----	-----	-----
15	2.9 to 0	112	337	530	691	835	1124	1767	3213	4016	4819	-----	-----	-----
	12.0	81	243	383	499	603	812	1275	2319	2898	3478	-----	-----	-----
	5.0	111	332	521	679	821	1105	1737	3158	3948	4737	-----	-----	-----
17	3.1 to 0	120	359	564	734	888	1195	1878	3415	4269	5123	-----	-----	-----
	15.0	73	219	344	448	542	730	1147	2086	2607	3129	-----	-----	-----
	10.0	115	346	544	709	858	1155	1815	3300	4125	4950	-----	-----	-----
	5.0	127	380	597	778	941	1266	1990	3619	4523	5428	-----	-----	-----
17	3.7 to 0	133	400	629	819	990	1333	2095	3809	4762	5714	-----	-----	-----

Note: It is recommended to keep valve outlet velocity below 30,000 ft./min.
Capacities are based on maximum C_v.

Types K1 and K4

Table 5. Types K1 and K4 Water Capacity in lbs/hr

PRESSURE, psi		VALVE SIZE AND PORT, NPS												
P1	P2	1/2 C	1/2 E	1/2 A	1/2 B	1/2 T	3/4	1	1-1/4	1-1/2	2	2-1/2	3	4
10	5	2	5	7	10	12	16	25	45	56	67	159	210	326
	3	2	6	9	11	14	19	29	53	66	79	188	249	386
15	10	2	5	7	10	12	16	25	45	56	67	159	210	326
	7	2	6	9	12	15	20	31	57	71	85	201	266	413
20	4	2	7	11	14	17	23	36	66	83	99	235	312	484
	15	2	5	7	10	12	16	25	45	56	67	159	210	326
	10	2	7	10	14	16	22	35	63	79	95	225	297	462
30	5	3	8	13	17	20	27	43	77	97	116	275	364	565
	22	2	6	9	12	15	20	31	57	71	85	201	266	413
	17	3	8	12	16	19	25	40	72	90	108	256	339	526
40	6	3	10	16	21	25	34	54	98	122	147	348	461	715
	25	3	8	13	17	20	27	43	77	97	116	275	364	565
	20	3	9	15	19	23	31	49	89	112	134	318	420	653
50	8	4	12	19	24	29	40	62	113	141	170	402	532	826
	35	3	8	13	17	20	27	43	77	97	116	275	364	565
	30	3	9	15	19	23	31	49	89	112	134	318	420	653
	25	4	11	17	22	26	35	55	100	125	150	355	470	730
60	10	4	13	21	27	33	44	70	126	158	190	449	595	923
	50	2	7	10	14	16	22	35	63	79	95	225	297	462
	40	3	9	15	19	23	31	49	89	112	134	318	420	653
	25	4	12	20	25	31	41	65	118	148	177	420	556	864
75	12	5	15	23	30	36	48	76	139	173	208	492	651	1012
	70	2	5	7	10	12	16	25	45	56	67	159	210	326
	50	4	11	17	22	26	35	55	100	125	150	355	470	730
	25	5	15	23	30	37	49	78	141	177	212	502	665	1032
100	15	5	16	26	33	40	54	85	155	194	232	550	728	1131
	75	4	11	17	22	26	35	55	100	125	150	355	470	730
	60	4	13	21	27	33	44	70	126	158	190	449	595	923
125	20	6	19	30	38	47	63	98	179	224	268	635	841	1306
	100	4	11	17	22	26	35	55	100	125	150	355	470	730
	75	5	15	23	30	37	49	78	141	177	212	502	665	1032
150	24	7	21	33	43	52	70	111	201	251	301	714	945	1467
	125	4	11	17	22	26	35	55	100	125	150	355	470	730
	100	5	15	23	30	37	49	78	141	177	212	502	665	1032
175	29	8	23	36	47	57	77	121	220	275	330	781	1034	1606
	150	4	11	17	22	26	35	55	100	125	150	355	470	730
	125	5	15	23	30	37	49	78	141	177	212	502	665	1032
200	100	6	18	29	37	45	61	95	173	217	260	615	814	1264
	34	8	25	39	51	62	83	131	237	297	356	843	1116	1734
	150	5	15	23	30	37	49	78	141	177	212	502	665	1032
225	100	7	21	33	43	52	70	110	200	250	300	710	940	1460
	39	9	27	42	55	66	89	140	254	317	381	901	1193	1853
	175	5	15	23	30	37	49	78	141	177	212	502	665	1032
250	100	8	23	37	48	58	78	123	224	280	335	800	1060	1600
	43	9	28	45	58	70	94	148	270	337	405	970	1280	1920
	200	5	15	23	30	37	49	78	141	177	212	502	665	1032
300	150	7	21	33	43	52	70	110	200	250	300	710	940	1460
	100	9	26	40	53	64	86	135	245	306	367	890	1170	1750
	48	10	30	47	61	74	99	156	284	355	426	1030	1360	2020
400	250	5	15	23	30	37	49	78	141	177	212	502	665	1032
	150	9	26	40	53	64	86	135	245	306	367	890	1170	1750
	58	11	33	51	67	81	109	171	311	389	467	1130	1490	2200
400	350	5	15	23	30	37	49	78	141	177	212	502	665	1032
	200	10	30	47	61	74	99	156	283	354	424	1030	1360	2020
	77	13	38	59	77	93	126	198	359	449	539	1300	1720	2520

Note: It is recommended to keep valve outlet velocity below 30,000 ft./min.
Capacities are based on maximum C_v.

Types K1 and K4

Table 6. Types K1 and K4 Water Capacity in kg/hr

PRESSURE, bar		VALVE SIZE AND PORT, DN												
P1	P2	15 C	15 E	15 A	15 B	15 T	20	25	32	40	50	65	80	100
0.7	0.3	0.4	1.1	1.8	2.4	2.8	3.8	6.0	10.9	13.7	16.4	38.8	51.4	79.9
	0.2	0.4	1.3	2.0	2.6	3.2	4.3	6.7	12.2	15.3	18.3	43.4	57.5	89.3
1	0.7	0.3	1.0	1.6	2.0	2.5	3.3	5.2	9.5	11.8	14.2	33.6	44.5	69.2
	0.5	0.4	1.3	2.0	2.6	3.2	4.3	6.7	12.2	15.3	18.3	43.4	57.5	89.3
	0.25	0.5	1.6	2.5	3.2	3.9	5.2	8.2	15.0	18.7	22.5	53.2	70.4	109.3
1.5	1	0.4	1.3	2.0	2.6	3.2	4.3	6.7	12.2	15.3	18.3	43.4	57.5	89.3
	0.7	0.5	1.6	2.6	3.3	4.0	5.4	8.5	15.5	19.3	23.2	54.9	72.7	112.9
	0.3	0.7	2.0	3.1	4.1	4.9	6.6	10.4	18.9	23.7	28.4	67.3	89.0	138.3
2	1.5	0.4	1.3	2.0	2.6	3.2	4.3	6.7	12.2	15.3	18.3	43.4	57.5	89.3
	1	0.6	1.8	2.9	3.7	4.5	6.1	9.5	17.3	21.6	25.9	61.4	81.3	126.3
	0.4	0.8	2.3	3.6	4.7	5.7	7.7	12.0	21.9	27.3	32.8	77.7	102.8	159.7
3	2	0.6	1.8	2.9	3.7	4.5	6.1	9.5	17.3	21.6	25.9	61.4	81.3	126.3
	1.5	0.7	2.2	3.5	4.6	5.5	7.4	11.7	21.2	26.5	31.8	75.2	99.6	154.6
	0.6	0.9	2.8	4.4	5.8	7.0	9.4	14.7	26.8	33.5	40.2	95.1	125.9	195.6
3.5	3	0.4	1.3	2.0	2.6	3.2	4.3	6.7	12.2	15.3	18.3	43.4	57.5	89.3
	2	0.7	2.2	3.5	4.6	5.5	7.4	11.7	21.2	26.5	31.8	75.2	99.6	154.6
	1.5	0.9	2.6	4.0	5.3	6.4	8.6	13.5	24.5	30.6	36.7	86.8	115.0	178.6
	0.7	1.0	3.0	4.8	6.2	7.5	10.1	15.9	28.9	36.2	43.4	102.7	136.0	211.3
4	3.5	0.4	1.3	2.0	2.6	3.2	4.3	6.7	12.2	15.3	18.3	43.4	57.5	89.3
	3	0.7	2.2	2.9	3.7	4.5	6.1	9.5	17.3	21.6	25.9	61.4	81.3	126.3
	2	0.9	2.6	4.0	5.3	6.4	8.6	13.5	24.5	30.6	36.7	86.8	115.0	178.6
	0.8	1.1	3.0	5.1	6.7	8.0	10.8	17.0	30.9	38.7	46.4	109.8	145.4	225.9
5	4	0.6	1.3	2.9	3.7	4.5	6.1	9.5	17.3	21.6	25.9	61.4	81.3	126.3
	3	0.9	1.8	4.0	5.3	6.4	8.6	13.5	24.5	30.6	36.7	86.8	115.0	178.6
	2	1.0	2.6	4.9	6.4	7.8	10.5	16.5	30.0	37.4	44.9	106.3	140.8	218.7
	1	1.2	3.6	5.7	7.4	9.0	12.1	19.0	34.6	43.2	51.9	122.8	162.6	252.5
6	5	0.6	1.8	2.9	3.7	4.5	6.1	9.5	17.3	21.6	25.9	61.4	81.3	126.3
	3	1.0	3.1	4.9	6.4	7.8	10.5	16.5	30.0	37.4	44.9	106.3	140.8	218.7
	1.2	1.3	4.0	6.3	8.1	9.9	13.3	20.8	37.9	47.4	56.8	134.5	178.1	276.6
8	6	0.9	2.6	4.0	5.3	6.4	8.6	13.5	24.5	30.6	36.7	86.8	115.0	178.6
	5	1.0	3.1	4.9	6.4	7.8	10.5	16.5	30.0	37.4	44.9	106.3	140.8	218.7
	1.6	1.5	4.6	7.2	9.4	11.4	15.3	24.1	43.8	54.7	65.6	155.3	205.6	319.4
10	8	0.9	2.6	4.0	5.3	6.4	8.6	13.5	24.5	30.6	36.7	86.8	115.0	178.6
	5	1.4	4.1	6.4	8.3	10.1	13.5	21.3	38.7	48.3	58.0	137.3	181.8	282.3
	2	1.7	5.1	8.1	10.5	12.7	17.1	26.9	48.9	61.1	73.4	173.7	229.9	357.1
12	10	0.9	2.6	4.0	5.3	6.4	8.6	13.5	24.5	30.6	36.7	86.8	115.0	178.6
	8	1.2	3.6	5.7	7.4	9.0	12.1	19.0	34.6	43.2	51.9	122.8	162.6	252.5
	5	1.6	4.8	7.6	9.8	11.9	16.0	25.2	45.8	57.2	68.6	162.4	215.1	334.0
	2.3	1.9	5.7	8.9	11.6	14.0	18.9	29.6	53.9	67.3	80.8	191.2	253.2	393.2
14	10	1.2	3.6	5.7	7.4	9.0	12.1	19.0	34.6	43.2	51.9	-----	-----	-----
	5	1.8	5.4	8.6	11.2	13.5	18.2	28.5	51.9	64.9	77.8	-----	-----	-----
	2.7	2.0	6.1	9.6	12.5	15.1	20.3	32.0	58.1	72.7	87.2	-----	-----	-----
15	12	1.0	3.1	4.9	6.4	7.8	10.5	16.5	30.0	37.4	44.9	-----	-----	-----
	5	1.9	5.7	9.0	11.8	14.2	19.1	30.1	54.7	68.4	82.0	-----	-----	-----
	2.9	2.1	6.3	9.9	12.9	15.6	21.1	33.1	60.2	75.2	90.2	-----	-----	-----
17	14	1.0	3.1	4.9	6.4	7.8	10.5	16.5	30.0	37.4	44.9	-----	-----	-----
	10	1.6	4.8	7.6	9.8	11.9	16.0	25.2	45.8	57.2	68.6	-----	-----	-----
	5	2.1	6.3	9.9	12.9	15.6	21.0	33.0	59.9	74.9	89.9	-----	-----	-----
	3.2	2.2	6.7	10.6	13.8	16.7	22.5	35.3	64.2	80.3	96.4	-----	-----	-----
20	17	1.0	3.1	4.9	6.4	7.8	10.5	16.5	30.0	37.4	44.9	-----	-----	-----
	14	1.5	4.4	7.0	9.1	11.0	14.8	23.3	42.4	53.0	63.5	-----	-----	-----
	3.9	2.4	7.3	11.5	14.9	18.0	24.3	38.2	69.4	86.7	104.1	-----	-----	-----
27	24	1.0	3.1	4.9	6.4	7.8	10.5	16.5	30.0	37.4	44.9	-----	-----	-----
	20	1.6	4.8	7.6	9.8	11.9	16.0	25.2	45.8	57.2	68.6	-----	-----	-----
	5.2	2.8	8.5	13.3	17.4	21.0	28.3	44.4	80.8	100.9	121.1	-----	-----	-----

Note: It is recommended to keep valve outlet velocity below 30,000 ft./min.
Capacities are based on maximum C_v.

Types K1 and K4

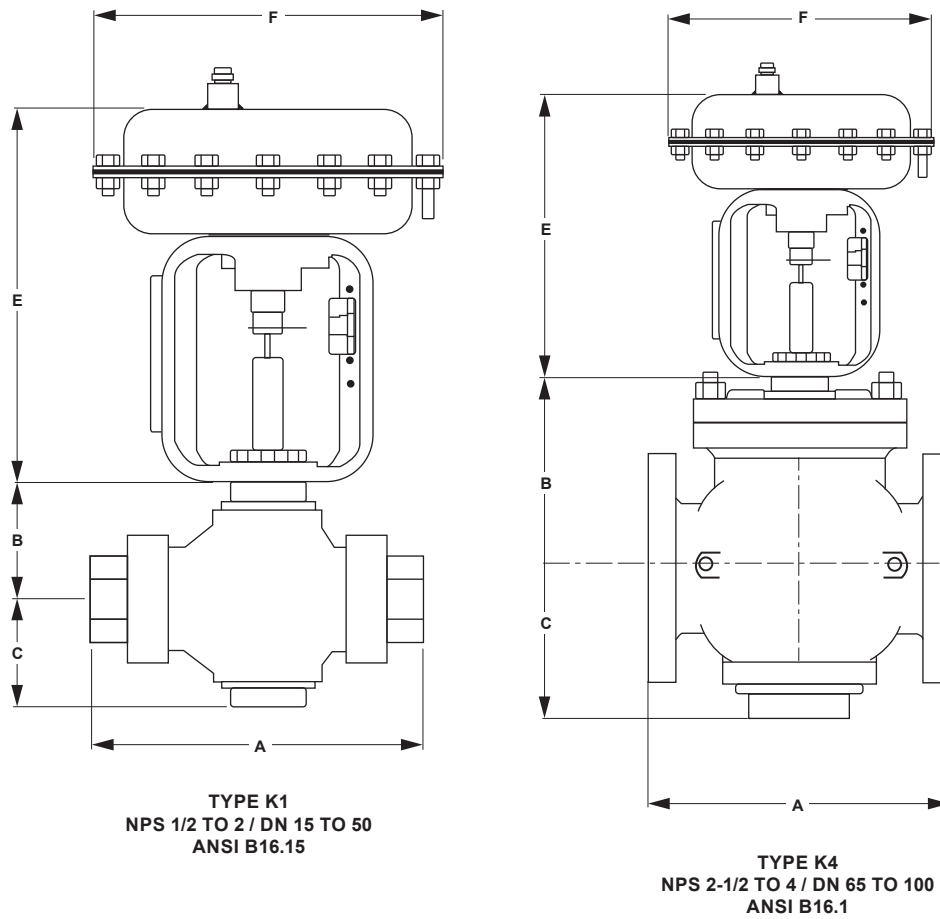

Figure 4. Types K1 and K4 Dimension

Table 7. Types K1 and K4 Dimension Table

SIZE		A		B		C		E, In. / mm		F, In. / mm		WEIGHT, lbs / kg	
NPS	DN	In.	mm	In.	mm	In.	mm	36 sq. in. / 0.02 sqm	60 sq. in. / 0.04 sqm	36 sq. in. / 0.02 sqm	60 sq. in. / 0.04 sqm	36 sq. in. / 0.02 sqm	60 sq. in. / 0.04 sqm
1/2 to 3/4	15 to 20	5-1/2	140	1-11/16	43	1-3/16	30	9-7/8 / 251	----	9-1/4 / 235	----	21 / 9.5	----
1	25	7-3/16	183	2-7/8	74	2-5/16	58	9-7/8 / 251	11-3/4 / 298	9-1/4 / 235	11-1/4 / 286	25-1/2 / 11.6	39 / 17
1-1/4 to 1-1/2	32 to 40	8-7/8	226	3-1/8	79	2-7/8	74	9-7/8 / 251	11-3/4 / 298	9-1/4 / 235	11-1/4 / 286	31-1/2 / 14.3	45 / 20
2	50	8-7/8	226	3-1/8	79	2-7/8	74	9-7/8 / 251	11-3/4 / 298	9-1/4 / 235	11-1/4 / 286	33-1/2 / 15.2	47 / 21
2-1/2	65	9-3/8	238	5-1/4	133	4-5/8	118	----	11-7/8 / 302	----	11-1/4 / 286	----	72 / 33
3	80	10	254	6-1/8	155	5-3/8	136	----	11-7/8 / 302	----	11-1/4 / 286	----	84 / 39
4	100	11-7/8	302	7-1/8	181	7-3/8	187	----	11-7/8 / 302	----	11-1/4 / 286	----	145 / 66

Types K1 and K4

Ordering Information

When ordering, complete the ordering guide on this page. Refer to the Specifications section on page 2.

Review the description to the right of each specification and the information in each referenced table or figure. Specify your choice whenever a selection is offered.

Ordering Guide

Type (Select One)

- Type K1
- Type K4

Body Material (Select One)

- Bronze
- Cast Iron

Body Size (Select One)

- NPS 1/2 / DN 15
- NPS 3/4 / DN 20
- NPS 1 / DN 25
- NPS 1-1/4 / DN 32
- NPS 1-1/2 / DN 40
- NPS 2 / DN 50
- NPS 2-1/2 / DN 65
- NPS 3 / DN 80
- NPS 4 / DN 100

End Connection Style (Select One)

- NPT
- CL125
- CL250

Options

- 36 sq. in. / 0.02 sqm actuators
- 60 sq. in. / 0.04 sqm actuators
- Electric Actuator

 [SpenceValve.com](https://www.SpenceValve.com)

Emerson Automation Solutions

Americas

McKinney, Texas 75070 USA
T +1 800 558 5853
+1 972 548 3574

Europe

Bologna 40013, Italy
T +39 051 419 0611

Asia Pacific

Singapore 128461, Singapore
T +65 6777 8211

Middle East and Africa

Dubai, United Arab Emirates
T +971 4 811 8100

VCBUL-15933 © 2021 Emerson Electric Co. All rights reserved. 11/21
Spence is a mark owned by one of the companies in the Emerson Automation Solutions business unit of Emerson Electric Co. The Emerson logo is a trademark and service mark of Emerson Electric Co. All other marks are property of their prospective owners.

The contents of this publication are presented for informational purposes only, and while every effort has been made to ensure their accuracy, they are not to be construed as warranties or guarantees, express or implied, regarding the products or services described herein or their use or applicability. All sales are governed by our terms and conditions, which are available upon request. We reserve the right to modify or improve the designs or specifications of such products at any time without notice.

Emerson Electric Co. does not assume responsibility for the selection, use or maintenance of any product. Responsibility for proper selection, use and maintenance of any Emerson Electric Co. product remains solely with the purchaser.